

OBD II B

TVS 

TVS **NTORQ 125**
RACE XPI
PLAY SMART

USER MANUAL



SCAN FOR 24X7
ROADSIDE ASSISTANCE NOW

WE GO THE DISTANCE WHEN IT COMES TO YOUR ASSISTANCE.

MAKE YOUR RIDES HASSLE-FREE AND STRESS-FREE
WITH SERVICE BEYOND JUST ASSISTANCE.

Sign up for our 24X7 Roadside Assistance and enjoy
quick and efficient service anytime, anywhere.

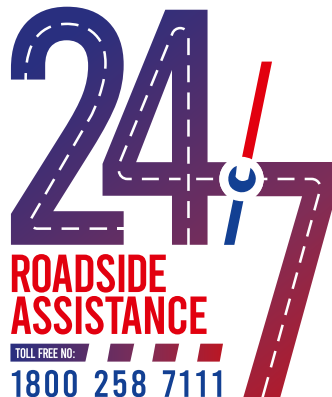



Drive In.

Drive Out.



**Say bye-bye to waiting time
for servicing your bike.**

Get your vehicle serviced in 1 hour at no additional cost. Contact your nearest Dealership for details. †

† Facility available at selected Dealerships only. Terms and conditions apply





Busy Life? Easy Servicing!

Now, service your bike anywhere, anytime.

- ★ Service the vehicle at your door step.
- ★ Available for regular maintenance or breakdown service only.
- ★ Offered at nominal convenience charges.

Contact your nearest Dealership for details.[†]

[†] Facility available at selected Dealerships only. Terms and conditions apply





Busy Life? Easy Servicing!

Now, service your bike anywhere, anytime.

- ★ Service the vehicle at your door step.
- ★ Available for regular maintenance or breakdown service only.
- ★ Offered at nominal convenience charges.

Contact your nearest Dealership for details.[†]

[†] Facility available at selected Dealerships only. Terms and conditions apply

CONTACT(S) FOR SUPPORT	1
UNIQUE FEATURES OF TVS NTOBQ 125 RACE XP	5
FOREWORD	10
NOTICE	11
SAFETY INFORMATION	12
RUNNING-IN INFORMATION	13
SAFE RIDING TIPS	14
KNOW YOUR TVS NTOBQ 125 RACE XP	18
RIDING YOUR TVS NTOBQ 125 RACE XP	64
MAINTENANCE	68
WARRANTY AND SERVICES	90
PRIVACY POLICY	97
TECHNICAL SPECIFICATIONS	103
GENERAL INFORMATION	106

Incase you need any Clarification please contact

TVS Motor Company Authorised Main Dealer / Authorised Dealer

Or

TVS Motor Company's Area Offices (flip over for addresses)

Or

Toll Free Number : 1800-258-7111

Email : customercare@tvsmotor.com

Disclaimer : TVS Motor Company or any of its officials / Authorized Main dealer / Authorized Dealer do not ask customers for bank / card / wallet details / authentication. In case you face any such claim, please report to the relevant local authorities immediately.

CONTACT AT OUR AREA OFFICES

TAMILNADU - 1

1. TVS Motor Company Limited

V Floor, Gee Gee Universal,
No. 2, MC Nichols Road,
Chetpet, Chennai - 600 031.
Phone : 044 - 28361651/28361654
Email : AO.Chennai@tvsmotor.com

TAMILNADU - 2

2. TVS Motor Company Limited

No. 10, 2nd floor,
Shree Shanmugapriya Towers,
Kannuswamy Street,
Behind Hotel Annapoorna,
R S Puram, Coimbatore - 641 002.
Phone : 0422 - 4350060/2541035
Email : AO.Coimbatore@tvsmotor.com

TAMILNADU - 3

3. TVS Motor Company Limited

Sastha Square, 2nd Floor,
No. 46/4,5, 46/6A6,
Bypass Road, Kalavasal,
Next to Bharat Petroleum, Ponmeni,
Chandragandhi Nagar,
Madurai - 625 016.
Email : AO.Madurai@tvsmotor.com

KERALA

4. TVS Motor Company Limited

Ambady Towers, Second Floor,
Door No. 27/631, A6,
Edappally-Pookkattupady Road,
Edappally PO., Cochin - 682 024.
Phone : 0484 - 2544578/2556938
Email : AO.Cochin@tvsmotor.com

KARNATAKA - 1

5. TVS Motor Company Limited

TVS Focus Towers, Plot No. 25 and 23,
Konappana Agrahara Village,
Begur Hobli, Electronics City phase 1,
26A, 1st Main Rd,
Bengaluru - 560 100.
Email : AO.Bangalore@tvsmotor.com

KARNATAKA - 2

6. TVS Motor Company Limited

5th Floor, Marvel Ecron building.
CTS No-4784/A1/B2
Gokul Road, Hubballi - 580 030.

TELANGANA

7. TVS Motor Company Limited

Rukumani Towers, First Floor,
No. 3-11-30, Plot No. 11,
Paigha Colony, Behind Anand Theater,
Secunderabad - 500 003.
Phone : 040 - 27840590/27844419
Email : AO.Hyderabad@tvsmotor.com

ANDHRA PRADESH

8. TVS Motor Company Limited

1st Floor, Passport Office Building,
Sri Venkateswara Theatre,
D.No. 38-8-45, MG road, Punnammathota,
Vijayawada - 520 010.
Email : AO.Vijayawada@tvsmotor.com

MAHARASHTRA - 1 & 2

9. TVS Motor Company Limited

Poloroche Business Avenue, #302,
3rd Floor, CTS No. 218/3, Airport Road,
Opposite Symbiosis Law School,
Lohegaon,
Pune - 411 047.
Email : AO.Pune@tvsmotor.com

MAHARASHTRA - 3**10. TVS Motor Company Limited**

No. 502B, 6th Floor, B Wing,
Shriram Shyam Towers,
Near LIC Square, Sardar,
Nagpur - 440 001.
Phone : 0712 - 2569932
Email : Service.Nagpur@tvs motor.com

CHATTISGARH**11. TVS Motor Company Limited**

Office No. B518- B527, 5th Floor,
Currency Tower, VIP Road Corner,
Raipur – 492 001.
Phone : 0771 - 4260006
Email : AO.Raipur@tvs motor.com

GUJARAT**12. TVS Motor Company Limited**

101-08, 11th Floor, Solitaire Connect,
Near Gallops Motors,
S G Highway, Makarba,
Ahmedabad – 380 051.
Phone : 0755 - 65443748
Email : AO.Ahmedabad@tvs motor.com

MADHYA PRADESH - 1**13. TVS Motor Company Limited**

No. 211-212, 2nd Floor,
Chinar Incube Business Centre,
Chinar Fortune City,
Near Brindhavan Dhaba,
Hosangabad Road,
Bhopal - 462 026.
Phone : 0755 - 2499406/2499306
Email : AO.Bhopal@tvs motor.com

MADHYA PRADESH - 2**14. TVS Motor Company Limited**

501, N R K Tech Park,
5th floor, Plot No. 9-C-C-A,
Scheme No. 94, Ring Road,
Indore - 452 010.
Phone : 9685558301
Email : AO.Indore@tvs motor.com

RAJASTHAN - 1 & 2**15. TVS Motor Company Limited**

Plot No. 17-18,
2nd Floor of National Motors Building,
Jhotwara Industrial Area,
Jaipur - 302 012.
Phone : 0141 - 5150901/5150902
Email : AO.Jaipur@tvs motor.com
AO.Udaipur@tvs motor.com

**DELHI, HARYANA, UTTAR PRADESH WEST
& UTTAR PRADESH HILLS****16. TVS Motor Company Limited**

Block D & E, Third Floor, "Golden-I",
Plot No. 11, Sector-Techzone - 4,
Gr. Noida West - 201 318.
Phone : 011 - 29834640/29834773
Email : AO.Delhi@tvs motor.com

PUNJAB & CHANDIGARH**17. TVS Motor Company Limited**

4th Floor, Royal Business Park,
Chandigarh Ambala Highway,
Zirkapur - 140 603.
Phone : 01762 - 464777/465777
Email : AO.Chandigarh@tvs motor.com

UTTAR PRADESH CENTRAL & EAST**18. TVS Motor Company Limited**

1st Floor, Cyber Tower, TC-34/V-2,
Vibhuti Khand, Gomti Nagar,
Lucknow - 226 010.
Phone : 0522 - 4918300/4918301
Email : AO.Lucknow@tvs motor.com

WEST BENGAL

19. TVS Motor Company Limited

Mediasiti, 6th Floor, Plot No. XI-4,
Salt Lake City, Electronic Complex,
Sector-V, PE & GP block, PO-Sech,
Bhawan, P S - Electronics Complex,
Kolkata - 700 091.
Email : AO.Kolkatta@tvsmotor.com

BIHAR

20. TVS Motor Company Limited

Sai Corporate Park, Block-A, 4th Floor,
Bailey Road, Rukanpura,
Patna - 800 014.
Email : AO.BNJ@tvsmotor.com

ORISSA

21. TVS Motor Company Limited

No. 303, 3rd Floor,
Creative Plaza, Rasulgarh,
Bhubaneshwar - 751 010.
Phone : 0674 - 2580019
Email : AO.Bhubaneshwar@tvsmotor.com

JHARKHAND

22. TVS Motor Company Limited

Second Floor, Lucas Service Building,
Argora Bypass Road,
Ranchi - 834 002.
Phone : 0651 - 2244715
Email : AO.Ranchi@tvsmotor.com

NORTH EAST STATES

23. TVS Motor Company Limited

147, Udayan, Ganesh Guri,
Near Hotel D Courtyard,
R G B. Road, Guwahati - 781 005.
Phone : 0361 - 2202030/2202031
Email : AO.Guwahati@tvsmotor.com

3-VALVE 125 CVTi - Revv ENGINE

Your scooter is India's 1st 125cc scooter having engine more than 10 ps power. The additional intake valve in your scooter helps in faster filling of petrol-air mixture and faster & better combustion.



FULLY DIGITAL CONNECTED INSTRUMENT CLUSTER WITH ON-BOARD DIAGNOSTIC

Your scooter is fitted with 'Fully Digital Connected Instrument Cluster'. This first-in class cluster housed perfectly in the headlamp housing of your scooter. An Engine Malfunction Indication lamp is added to glow whenever any engine related fault is present in vehicle.



RIDE MODES

You can change the mode of the vehicle on the fly. Street and Race are two modes of your scooter. For city ride, try using Street mode and for a powerful ride, use Race mode.

SMARTXONNECT-BLUE TOOTH CONNECTIVITY (First Time in Scooters)

The connected instrument cluster of your scooter has a inbuilt Bluetooth® connectivity through which you can connect your Android™ smart phone / iPhone® to access the features like caller ID, SMS and missed call notification, navigation in the cluster and voice assist, ride stats share and incase of Android smart phone the last parked location of the vehicle.

'TVS intelliGO' SWITCH

An exclusive 'intelliGO Switch' is provided to switch 'OFF' and 'ON' the 'TVS intelliGo' system as and when required.



ECONOMETER®

Your scooter's connected instrument cluster has an 'ECONOMETER®' which indicates whether you are riding in Economy Mode or Power Mode. This is a unique feature of your scooter which guides you to ride your scooter fuel efficiently.



PASS-BY SWITCH

'Pass-by Switch' allows you to easily switch between high and low beam of head lamp with easy press and auto release. It is helpful especially while overtaking.



The same pass-by switch is used to operate head lamp low / high beam continuous glowing.

LED HEAD LAMP CUM POSITION LAMP WITH ALL TIME HEAD LAMP ON (AHO)

TVS NTORQ 125 Race XP Race Edition comes with premium LED headlamp cum position lamp. Efficient and bright head lamp gives NTORQ a totally upgraded Look and style with better visibility for night rides.



EXTERNAL FUEL FILL

This is an exclusive facility which allows you to fill petrol without even getting out of your seat.



LOW FUEL INDICATOR

'Low Fuel Indicator' is yet another unique feature of your scooter which indicates you to refill the fuel when the fuel in the tank goes below minimum safe level.



TEXTURED FLOORBOARD

Your scooter comes with a stylish textured floor board.



PETAL DISC BRAKE

Your scooter is fitted with '220 mm Roto - Petal Disc' at the front for effective braking and safe riding even at higher speeds.



DIAMOND - CUT ALLOY WHEELS

Your scooter has sporty diamond cut alloy wheels.



CHUNKY TUBELESS TYRES

'Chunky Tubeless Tyres' are another important unique feature in your scooter. Tubeless tyres reduces the chances of getting punctured. Even if there is a puncture, sudden leakage of air is avoided, thereby provide better safety and convenience. It is also very easy to repair the punctured tyres.



LARGER ALLOY WHEELS

'Larger Alloy Wheels' with high mechanical advantage gives progressive braking of your scooter, results in best-in-class 'Shortest Distance' braking. It also provides superior comfort in bad road conditions.



PATENTED E-Z CENTRE STAND

'E-Z Centre Stand' of your scooter reduces the effort required to place the scooter on stand.



RETRACTABLE BAG HOOKS

Your scooter has two retractable 'Bag Hooks' to carry light luggage like carry bags weighing upto 3 kg. One hook is located below the handle bar on the rear panel and the other one is located on the cover front below the front end of the seat.



LED TAIL LAMP-CUM-BRAKE LAMP

Your scooter has a 'LED Tail Lamp-Cum-Brake Lamp' for better visibility and stylish looks.



PARKING BRAKE (Rear Brake Lock)

'Parking Brake' is another safety feature which protects your scooter from falling due to wheel rotation when it is parked with the side stand on a slope.



HAZARD SWITCH

TVS NATORQ 125 Race XP comes with a hazard switch which can be used whenever it is necessary to park the scooter in a hazardous location due to emergency situation.



UNDER-SEAT STORAGE (Utility Box)

Your scooter has a 20 litre 'Under-Seat Storage' space to carry your luggage belongings, full face helmet etc.



SMART PHONE CHARGER

Your scooter has a 'Smart Phone Charger' which enables you to charge your mobile phone even when you are traveling. Use the charger only when the engine running.



HELMET HOOKS

Your scooter has two 'Helmet Hooks' under the seat assembly at the front end of utility box to secure your helmet.

Your helmets can be hung in this hooks when the vehicle's utility box is filled with your things.



ACCESSORIES FOR YOUR VEHICLE

To enhance the look, convenience and safety, the below listed accessories available for your scooter.

Ask your Dealer to fix this accessory on your scooter but it will be charged additional.

- Front glove box
- Beeper

Welcome to the NTORQian Tribe!!

If you are reading this, you now own a revolutionary riding experience engineered to shatter barriers and designed to thrill.

TVS NTORQ 125 RACE XP

India's 1st 125cc scooter with more than 10hp power

India's 1st scooter with Dual Ride Modes

India's 1st scooter with Voice Assist and the next-gen SmartXconnect technology

Race-inspired design, to bring out the racer in you

The TVS NTORQ 125 Race XP races ahead of the curve with Xtra Power, to give you the race track experience in your everyday ride.

This manual is your guide to unlocking the complete potential of your TVS NTORQ 125 Race XP.

And of course, we're sure that a true rider like you will get your Race XP regularly serviced, only at TVS Motor Company's Authorised Main Dealer / Authorised Dealer.

Go ahead, you're ready to Rev Up with Race XP

TVS MOTOR COMPANY LIMITED

Take time to familiarize yourself with your TVS NTORQ 125 Race XP and its performance characteristics.

This manual is designed to help you to maximize the performance of your TVS NTORQ 125 Race XP. Inside this manual, you'll find essential guidance on riding techniques and maintenance tips. By following these instructions carefully, you can ensure optimal performance and longevity of your vehicle.

Get familiarised with the operation of your TVS NTORQ 125 Race XP for maximum safety and pleasure. The better you know your vehicle, the more pleasure you will experience riding your new vehicle. Ensure that anyone else riding your TVS NTORQ 125 Race XP does the same.

All information, illustrations, photographs and specifications contained in this User Manual are based on the latest product information available at the time of this publication. TVS Motor Company Limited may, however, incorporate modifications or improvements on its vehicles at any time without notice, and therefore, in such events it is possible that the relevant part of the User Manual does not apply to your vehicle.

Prior permission of TVS Motor Company Limited is required for quoting, copying or reproducing any part of this User Manual.

Note

Accessories shown in the picture may not be part of the standard equipment. Pictures shown in this manual are of TVS NTORQ 125 Race XP disc brake version unless specified.

TVS NTORQ 125 Race XP is provided with All time Head lamp ON (AHO). The head lamp glows automatically once the engine is started without activating any other switch.

Since your vehicle is fitted with side stand cut-off system ensure to retract the side stand before starting the vehicle.

Riding this vehicle safely is a key responsibility of the rider. To support informed and safe decision-making, this User Manual provides essential operating procedures and safety-related information. These guidelines are intended to alert you to potential hazards that could cause harm to you or others. However, since it's not possible to cover every possible risk associated with operating or maintaining the vehicle, it's important to exercise sound judgment at all times.

You will find critical safety instructions presented in specific formats throughout the User Manual. These formats use particular terms that convey the following meanings:

Warning

Disregarding this message might result in injury to the rider or deadly accidents.

Caution

This message indicates special procedures or precautions to be followed to avoid damage to the vehicle.

Note

This message provides further clarification for clear understanding of any particular information.

The first 1000 km is a crucial part for the life of your TVS NTORQ 125 Race XP. Proper running-in operation during this period helps in ensuring a maximum life and smooth performance of your scooter.

The reliability and overall performance of your TVS NTORQ 125 Race XP greatly depend on the care taken during the initial running-in period. During this period, it is especially important that you avoid operating the engine in high speed (RPM), as this can place the engine parts under undue stress. To ensure optimal engine health and longevity, please adhere to the recommended maximum speed limits during the running-in phase:

Maximum 50 km/h speed upto 1000 km for TVS NTORQ 125 Race XP (vary the engine speed for better mating of parts).

The first free service at 500 ~ 750 km or 2 months (whichever occurs earlier) is most important. During running-in period all the engine components and other parts will have set in. All adjustments to be restored, all fasteners to be tightened. Engine and transmission oil to be replaced. Timely performance of the first free service will ensure optimum service life and performance of the engine.



Caution

Replacing the engine and transmission oil during first free service is most important for better life of engine. Always use TVS TRU4 SKUUTA oil (SAE10W30 API-SL, JASO MB) for better performance and life.

SAFE RIDING RECOMMENDATIONS

Any two wheeler riding requires some precautions to be taken to ensure the safety of the rider, pillion rider and other road users. These precautions are:

Familiarise yourself with new TVS NTORQ 125 Race XP

Riding skill and your mechanical knowledge forms the foundation of safe riding practices. We suggest you to practice riding TVS NTORQ 125 Race XP in a low-traffic condition until you are thoroughly familiar with your vehicle and its controls. Remember practice makes you perfect.

Riding apparel

Loose, fancy clothing can be uncomfortable and unsafe when riding a two-wheeler. Choose good quality two wheeler riding apparel.

Know your limits

Ride within the boundaries of your own skill at all times. Knowing these limits and staying within them will help you avoid accidents.

Warning

Two wheeler safety starts with wearing a good quality helmet. One of the most serious injuries that can happen is a head injury. Always wear an ISI approved helmet that should fit your head comfortably and securely. You should also have good quality goggles to protect your eyes and help your vision.

To prevent or minimize accident, never consume alcohol or drugs before or during the operation of your vehicle. Even minimal consumption of these will affect the rider's ability to control the vehicle.

Posture

Proper vehicle riding starts with proper posture.

1. Keep your elbows relaxed and flexible.
2. Sit and adjust yourself on seat so that arms and shoulders are relaxed.
3. Look widely instead of gazing at one point.

Warning

One-hand riding is dangerous. Keep both hands firmly on the handle bar and both feet securely on the floor board. Under no circumstances should both the hands be removed from the handle bar, as it is very dangerous.

Avoid use of mobile phones while riding as it could lead to fatal accident.

Slow down to a safe speed before negotiating a corner. If this is the first time that you are riding a vehicle of this type, we suggest that you practice on a safe, open area to thoroughly familiarise with the operation of the vehicle.

Cornering

When cornering, centrifugal force works in a direction perpendicular to the direction in which the vehicle is moving. Centrifugal force increases in proportion with speed and the radius of the corner.

During cornering, reduce speed so as to lessen the effects of centrifugal force. By all means, avoid abrupt application of brake or sudden steering.

Braking

For safe riding, it is very important to master the braking techniques.

1. Close / release the throttle.
2. Hold the vehicle upright as you apply the brake.
3. Progressive application of brakes is safer.
4. **Apply both the brakes. 'SBT' provides additional braking even when 'Only Rear brake' is applied, But applying 'Both the brakes' helps you to use the full potential of the brakes.**
5. Riding down hills, while cornering and wet roads, close throttle and come to a slower speed to avoid the loss of control over the vehicle due to skidding.

Causes for poor braking

1. If the brake shoes / pads or drum / disc are worn out or if there is water or oil on them, sufficient friction does not develop and brakes do not work well.
2. Even when the brake works normally, if the road surface is wet or the tyre surface is worn-out, tyres do not take a firm hold on the surface, increasing the stopping distance.
3. Approximately 60% braking effect is from front brake. **Non-usage of front brake causes poor braking.**

Warning

As the vehicle speed increases, the stopping distance also increases progressively. Be sure that, you have sufficient distance between you and the vehicle or obstruction ahead of you.

Using only the front or rear brake is dangerous and can cause skidding and loss of control. Apply both the brakes together and with great care on a wet road or other slippery surfaces. Any abrupt braking on slippery or irregular roads can cause loss of rider control.

ACCESSORY INSTALLATION AND SAFETY TIPS

Use extreme caution while selecting and installing the accessories for your scooter.

The addition of **unsuitable accessories can lead to unsafe operating conditions.** Your friendly Dealer will assist you in selecting quality accessories and installing them correctly.

While selecting the accessories, make sure that the accessories **should not obstruct lighting, steering, suspension level and ground clearance.**

Additional electrical equipment is not acceptable as it will void the warranty terms of the vehicle.

EMISSION CONTROL

All the TVS vehicles are tested in the factory for optimum fuel efficiency and CO levels. If the vehicle needs any adjustments, please consult nearest TVS Motor Company Authorised Main Dealer or Authorised Dealer.

While adequate care is exercised at the factory to ensure that the emissions are within the limits, it is essential for the user to always maintain the scooter in good condition by getting it periodically checked and serviced by TVS Motor Company Authorised Main Dealer / Authorised Dealer so that the emission and fuel consumption levels are maintained as per norms.

Crankcase emission control system

The engine of new TVS NTORQ 125 Race XP is equipped with a closed crankcase system to prevent discharging crankcase emissions into the atmosphere. Blow-by gas is returned to the combustion chamber through the air cleaner and the fuel system.

Evaporative Emission Control System

TVS NTORQ 125 Race XP is equipped with an evaporative emission control system which consists of a canister and associated piping. This system prevents the escape of fuel vapors from the fuel tank.

Warning

If there is any abnormal jerk, startability issue are felt in the vehicle or noise due to sudden escape of gas during opening of fuel tank cap, immediately report to the TVS Motor Company Authorised Main Dealer / Authorised Dealer.

Note

Your vehicle is tested and certified for emission which meets BSVI emission norms and is valid for initial 12 months from the date of purchase. Get your vehicle certified by the Government authorised emission testing station after initial 12 months of usage. And ensure to get the vehicle certified on expiry of the certificate obtained.

Fill fuel to the marked reference as mentioned in warning sticker, to ensure proper functioning of Evaporative Emission Control system.

VEHICLE IDENTIFICATION NUMBER

The frame and engine serial numbers are the only means of identifying your vehicle from others of the same model and type. They are also required to assist your Dealer for ordering parts or referring to special information.



The frame serial number is stamped on the frame, at the rear end below the seat assembly. Open the seat assembly to read the frame number.



The engine serial number is stamped on the left side of the engine, at the bottom, near center stand mounting. See bottom to read serial number.

LOCATION OF PARTS - VEHICLE LEFT SIDE



1. Disc plate front
2. Front wheel axle
3. Caliper assembly front
4. Side stand
5. Pillion foot rest L
6. Rear brake adjuster nut
7. Lady foot rest - foldable*
8. Seat cum fuel tank lock

* Mandatory accessory will be charged extra

LOCATION OF PARTS - VEHICLE RIGHT SIDE

1. Seat assembly
2. Muffler assembly
3. Gauge oil level
4. Pillion foot rest R
5. Cover front
6. Bag hook (rear)
7. Front wheel axle nut

LOCATION OF PARTS - VEHICLE FRONT & REAR



FRONT

1. Head lamp assembly
2. DRL
3. Turn signal lamp front R
4. Turn signal lamp front L

REAR

1. Tail / brake lamp
2. Turn signal lamp rear R
3. License plate lamp
4. Transmission oil level screw
5. Turn signal lamp rear L
6. Pillion handle

License plates are mandatory accessory will be charged extra

CONTROL KEY

TVS NTORQ 125 Race XP comes with a pair of identical control keys. These keys are to operate ignition cum steering lock, fuel tank cap and seat lock.

IGNITION CUM STEERING LOCK

The ignition lock enables and disables the electrical circuit and steering lock. The three positions of the lock are described below.

1. 'OFF' position

All the electrical circuits are turned 'OFF' in this position. Engine will not start. Key can be taken out.

2. 'ON' position

In this position, all the electrical circuits are turned 'ON' and the engine can be started now. Key cannot be removed in this position.

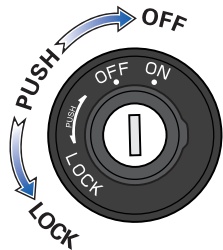

Ensure that the engine kill switch is in 'RUN' mode before starting the engine after the ignition ON. The connected instrument cluster and warning lights perform the self-diagnostic cycle once upon activation.

3. 'LOCK' position

TVS NTORQ 125 Race XP steering can be locked in both 'left' and 'right' directions.

Turn the handlebar to the 'left' or 'right'. Press the key 'IN' and rotate it to the 'LOCK' position from 'OFF' position. All electrical circuits are deactivated and the steering is locked. The control key can be removed from the lock.

Insert the key into the lock and press the key 'IN' and turn it to 'OFF' or 'ON' position to unlock the steering.

Note

When you switch on the key, the pump priming noise may be heard, which is normal. Avoid frequent SWITCH-OFF & ON of ignition key, to avoid unnecessary run of fuel pump.

By default when the scooter is switched ON for the first time, it starts with 'Street Mode'.

Note

The connected instrument cluster background illumination, day time running lamp (DRL) and tail lamp glow automatically once the ignition key is turned 'ON' without activating any other switches. When the ignition switch is turned 'ON' the connected instrument cluster performs self diagnostic cycle. Wait till the message 'HELLO RIDER' or name of the person given in the app is displayed.

Warning

Never attempt to move the vehicle when the steering is locked, you may lose balance.

Caution

Leaving the ignition cum steering lock in 'ON' position for a prolonged time will drain the battery when the vehicle is not in use. Switch 'OFF' and take the control key out when the vehicle is not in use.



Always lock the steering while parking for safety.

HANDLE BAR LEFT SIDE

1. Horn switch

Press the switch '  ' to operate the horn.

2. Turn signal lamp switch

Slide the turn signal lamp switch to left '  ' or right side '  ' to operate respective turn signal lamps (LH / RH). Press the center button of the switch to turn 'OFF'.

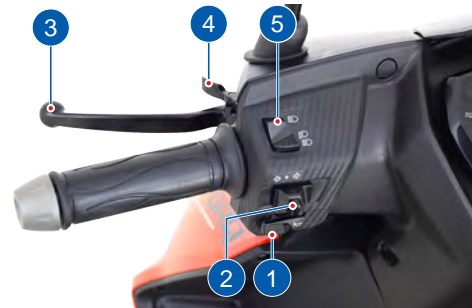

Warning

Always use the appropriate turn signal lamps when you intend to change lanes or take turns. Be sure to switch it 'OFF' after negotiating the lanes or turns.

3. Left hand brake lever (SBS brake lever)

Synchronised Braking System (SBS) can be operated by pressing the left hand brake lever gently towards the handle grip. SBS technology helps to operate both front and rear brakes by distributing the force optimally between the two braking system.

4. Rear brake lock lever

Brake lock protects your vehicle from rolling-off, when parked on side stand (or) helps you to relax while waiting in a long traffic signal (or) a slope.

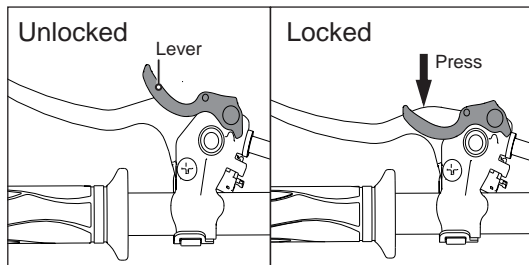



Warning

Since your vehicle is fitted with SBS brake system it is essential to maintain the brake system in good condition. Adjust the brakes system at regular intervals for the proper working of SBS.

To activate brake lock, press the brake lever almost half towards the grip and hold, then press the parking brake lever to maximum and release the brake lever slowly. Ensure the brake is locked properly. Pressing the brake lever further releases the brake lock automatically.

5. High/low beam cum pass by switch

With the head lamp 'ON' (incase of Race edition, headlamp gets on automatically once the engine is started), press the switch towards '  ' to operate head lamp high beam or press it towards '  ' to operate head lamp low beam.

TVS NTORQ 125 Race XP has a combined switch for head lamp 'high / low' beam and pass by. To operate the pass by, keep the switch in 'low beam' position, press gently and release. This makes the head lamp high beam to flash and signal the approaching vehicle. The pass by signal can be used while overtaking during day time.

Warning

Ensure brake lock is released before riding the vehicle.

Use appropriate head lamp beam 'high / low' as per the traffic and road conditions for your safety and avoid inconvenience to other riders.

HANDLE BAR RIGHT SIDE

1. Right hand brake lever

In case of disc brake vehicles the right hand brake lever controls a hydraulic circuit while squeezing and the hydraulic circuit operates the front brake system. Else the brake system works directly. The brake lamp glows on application of front brake.

2. Throttle grip

Engine speed is controlled by the rotation of the throttle grip. Twist it towards you to increase the engine speed and twist it away from you or release it to decrease the engine speed.

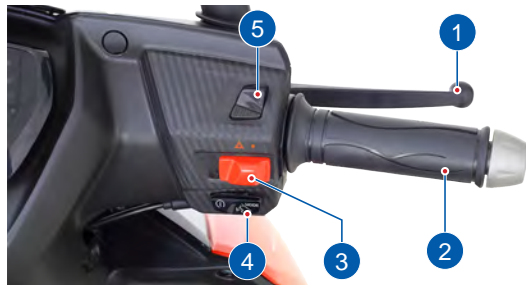

3. Hazard switch

Whenever it is necessary to park the scooter in a hazardous location due to emergency situation, press the hazard switch to '▲' position with the ignition 'ON' condition. This makes all the turn signal lamps to flash simultaneously to make other road users aware of presence of the vehicle.

Warning

Usage of hazard switch in engine 'OFF' condition can lead to battery drain and can affect the electric startability of the vehicle.

4. Electric starter / mode selection

Retract the side stand and press the starter switch '⚡' to start the engine electrically along with the application of either front or rear brake.

Once the vehicle is started (engine is ON) the same switch can be used to change the 'MODE'.



Simple press of the switch changes the ride mode when engine is started.

 **Note**

When the engine is not started the 'Electric starter / mode selection switch' used for start the engine electrically. Once the engine is started the switch is used to activate the voice assist or to change the ride mode.

Voice Assist will only activate when there is a audio device connected with your mobile phone and paired with TVS Connect App. Audio device can be connected by wire or wireless bluetooth headphone.

5. 'TVS intelliGO' switch

To activate the 'TVS intelliGO' system, set the intelliGo switch to '  ' position. The intelliGo indicator '  ' of the speedometer glows for 2 seconds.

To deactivate 'TVS intelliGO' system, set the intelliGo switch to '  ' position.

 **Note**

Before starting, ensure to turn 'ON' the engine kill switch and retract the side stand. Release the electric starter switch immediately after the engine has started.

CONNECTED INSTRUMENT CLUSTER

Your TVS NTORQ 125 Race XP is provided with a fully digital connected instrument cluster featuring a reverse RLCD display and a range of innovative features, including Bluetooth® connectivity, Average fuel economy, iGO assist, Time indication, Distance to empty, Digital odometer, Trip meters (A, B, and F), Service reminder, Helmet indication, Economy and Power mode indications, side stand indication etc.

Upon ignition, after self-check, the users are greeted with a welcoming message as illustrated, if your smart phone is not paired with the speedometer.

HELLO
RIDER

But if your phone was paired earlier, then the name of the person as stored in the app (if stored) will be displayed instead of 'RIDER'.

Note

The name stored in the app has more than 11 characters the connected speedometer scrolls the name from right to left at readable speed.

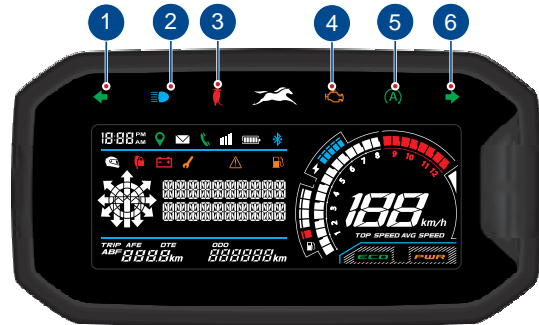

1. Turn signal indicator lamp left (←)

Flashes when the left side turn signal indication is activated.

2. High beam indicator lamp (≡D)

Glow when the headlamp high beam is activated.

3. Side stand indicator (🚲)

The side stand warning indicator turns 'ON' to alert you whenever the vehicle's side stand is deployed (vehicle in parked condition).

Note

If the side stand is deployed, the vehicle will not start. Retract the side stand to start the vehicle. If there is an error in the side stand sensor, the indication will not blink and the vehicle will not start. In such a condition, please visit the nearest TVS Motor Company Authorised Main Dealer / Authorised Dealer.

4. Malfunction indicator lamp - MIL ()

MIL will 'Blink' when the ECU detects misfire and will be 'ON' when the ECU detects any fault in the system.

If the malfunction indicator lamp '  ' is glowing / blinking continually even after the starting the engine, immediately contact the nearest TVS Motor Company Authorised Main Dealer / Authorised Dealer. Please remember that the 'TVS intelliGO' system will not work if the MIL indicator is 'ON'.

Note

The malfunction indicator will continue to remain switched 'ON' after self checking of cluster until the engine is started. But soon after starting the engine this indicates gets 'OFF' if there is no malfunction is detected in the system.

5. 'TVS intelliGO' ()

Fuel is consumed unnecessarily when the engine is in idling (eg. In traffic signals) as there is no useful output to the wheel. It contributes to emission and decreases mileage of the vehicle considerably.

To overcome this issue 'TVS intelliGO' system is introduced in TVS NTORQ 125 Race XP to automatically shut down the engine when it is kept idling for long and restart from stop condition by simply pressing the Brake and giving Throttle. The vehicle also can be restarted using 'Electric start' if required. **We recommend to use of this 'TVS intelliGO' system to improve the fuel economy and reduces emission.**

Activation of 'TVS intelliGO' system:

'TVS intelliGO' system gets activated when the following requirements are satisfied,

1. 'TVS intelliGO' switch is in '  ' position
2. Engine is warmed up and
3. When the vehicle speed is more than 5 kmph.

When the vehicle has met the above conditions, the 'TVS IntelliGO' system gets enabled and the IntelliGO indicator 'A' in the speedometer glows and informs you that the vehicle has entered 'IntelliGO' loop and the engine will stop automatically at upcoming vehicle idling condition.

Once the vehicle enters the idling condition, the IntelliGO indicator starts blinking instead of glowing and engine stops after predetermined time. The IntelliGO indicator starts glowing during the engine stop to indicate you that the vehicle has stopped due to 'IntelliGO' system.

The vehicle stopped by 'TVS IntelliGO' system can be restarted at any time within 5 mins from the stop of the vehicle by IntelliGO feature in a simple way of applying Brake and Throttle blip.

Deactivation of 'IntelliGO' system:

'Idle start stop' system will be deactivated if the IntelliGO switch is positioned at 'A' position.

If the ISG malfunction indicator or MIL indicator is 'ON' then the IntelliGO system will not work not get activated.

If there is 5 unsuccessful start of the vehicle either by electric start or by IntelliGO restart method in one ignition key 'ON' cycle then the IntelliGO will not get activated.

If vehicle is not restarted within 5 mins from idle stop, then IntelliGO will be deactivated.

Prolonged idling:

When vehicle is in idling with the engine temperature high enough to maintain stable engine idling rpm and the IntelliGO switch is in 'A' position, then the IntelliGO will be activated.

When 'TVS IntelliGO' is enabled, the IntelliGO lamp glows for 5 seconds and then blinks for predetermined time and then the engine stops.

IntelliGO lamp will glow after vehicle has stopped due to this feature. By applying Brake and Throttle blip the engine can be restarted again.

6. Turn signal indicator left (←)

Flashes when the 'left' side turn signal indication is activated.

Note

Ensure that the brake free play is adjusted and it is within the limit for the proper working of 'TVS intelliGO'.

Vehicle can be started at any point of time using 'electric start' when the engine is stall condition and the ignition key is in 'ON' condition. The 'TVS intelliGO' switch can be activated / deactivated at any point of time.

If vehicle is stopped by 'TVS intelliGO' system, and the 'TVS intelliGO' switch is toggled from 'ON' to 'OFF' and back to 'ON', the intelliGO system will be deactivated and the vehicle can be restarted only by the 'electric start'.

7. Trip meter A, B & F / 8. Odometer / 9. Fuel gauge / 10. Economy and power mode indicators / 11. Speedometer / Average speed / Top speed



7a. Trip meter (A & B)

Trip meter indicates the trip distance traveled in kilometer. The digit after the dot mark denotes the one tenth of a kilometer.

Provision to measure two different distance 'TRIP A' or 'TRIP B' is provided for the users to use as per their convenience.

TRIP A **60.3 km** **TRIP B** **57.3 km**

Refer page no 40 for the resetting procedure of Trip meter.

7b. Trip F

'Trip F' function displays the distance travelled after the low fuel indicator '  ' starts to glow and the fuel indicators last bar starts blinking. The display switches automatically to the 'TRIP F' mode after 0.5 km run of the vehicle and the low fuel indicator starts counting from 0 km.

If the fuel level remains in minimum safe level, the reading is saved even after the ignition 'OFF'.

The count stops and clears automatically after a certain distance of run and when the fuel level rises above minimum safe level.

'TRIP F' meter cannot be activated or deactivated manually. At every ignition 'ON', 'TRIP F' meter will get enabled automatically until fuel level is reached above minimum safe level.



Trip 

8. Odometer

Registers and displays the total distance covered by the vehicle in kilometers.

ODO
5306 km

Note

If the ODO / TRIP A or B / TRIP F meter (whichever is in display) segments are flashing and a error message as shown below is displayed on the notification area, contact nearest TVS Motor Company Authorised Main Dealer / Authorised Dealer.

CHECK
SPEEDSENSOR

9. Fuel gauge

Digital bars indicates the approximate fuel quantity available in fuel tank. There are five bars to indicate the quantity of fuel available in the fuel tank. All the five bars will be displayed when the fuel in the tank reaches above 4.35 liters approximately (full tank).



When the fuel reaches half tank (3.1 liters approx.) the fuel gauge displays only three bars as shown.



The fuel gauge shows only single bar when the fuel reaches reserve level (1.55 liters approx.). Refill the fuel immediately.



Once the fuel level reaches 1.05 liters approximately, the last bar will blink and low fuel indication glows continuously.



If all the fuel level bars in the cluster are starts blinking Contact nearest TVS Motor Company Authorised Main Dealer / Authorised Dealer.

Caution

*Before turning the ignition key to 'ON' position, ensure the availability of adequate fuel in the tank. That is LOW FUEL INDICATION shall not come 'ON'; before the start of the vehicle. **To avoid dry run of fuel pump, never run vehicle beyond 5 km, after LOW FUEL INDICATION.***

Note

Fuel level shown is only for reference purpose and users are not encouraged to calculate mileage of the vehicle using the same.

If the side stand is in 'ON' condition, fuel gauge reading will not get updated. The fuel gauge reading gets updated once the side stand is released.

If all the fuel level bars of the connected instrument cluster starts blinking and the below error message is shown in the notification area of the speedometer, contact nearest TVS Motor Company Authorised Main Dealer / Authorised Dealer.

CHECK
FUEL SENSOR

10. Economy and power mode indicators

Economy indicator ' **ECO** ' indicates that the vehicle is running in economy mode which will give you a better fuel economy.

Power mode indicator ' **PWR** ' indicates that the vehicle is running in power mode.

Note

Always ride the vehicle in 'Economy Mode' for better fuel efficiency.

Whenever the engine is kept running in idle mode for more than 20 seconds approximately, the power mode indicator blinks and informs you that the fuel is getting wasted, please turn on intelligo feature or the engine needs to be switched 'OFF' to save the fuel. The power mode indicator blinking (power mode) changes to green light glowing (economy mode) when the throttle position is changed / increased from idling.

11a. Speedometer

Indicates the vehicle speed in kilometer per hour.



11b. Average speed

Indicates the average speed in that the vehicle has been traveled in kilometer per hour.



11c. Top speed

Indicates the top speed so far that the vehicle has clocked in kilometer per hour.



The current ride's top speed continues to blink within the tachometer region while the vehicle speed is less than 2 km/h. When the speed exceeds 2 km/h, it automatically deactivates.

Note

The average speed and AFE value displayed are estimated values and the actual value may differ from the displayed one.

12. Notification area / 13. Navigation window (pictogram) 14. Helmet icon / 15. Low battery indicator / 16. Service reminder / 17. ISG malfunction indicator / 18. Low fuel indication

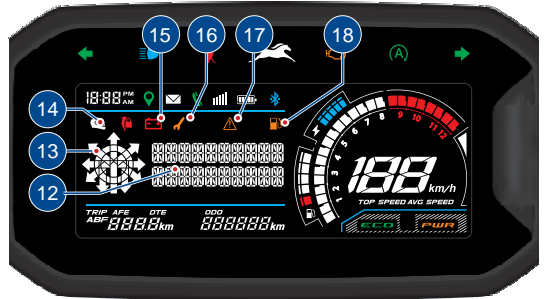

12. Notification area

This is a general purpose notification area where the greeting message, various informations and warnings are displayed.



14. Navigation window (pictogram)

Once the navigation assist is turned 'ON', your TVS NTORQ 125 Race XP speedometer displays "Navigation assist ON" and enters into navigation window and displays the turn by turn navigation instruction with a simple and elegant graphical representation.



15. Helmet icon

With every ignition 'ON', helmet icon '  ' blinks for 10 seconds on the right side of the digital speedometer to remind the rider to wear a helmet.

15. Low battery indicator

An icon with battery symbol '  ' glows when the battery charge is too low.

Following error message also will be popped-up in the notification area when the low battery symbol is turned 'ON'.

LOW
BATTERY

Get the battery checked at TVS Motor Company Authorised Main Dealer / Authorised Dealer.

16. Service reminder ()

If the service is due, whenever the ignition switch is turned 'ON', an icon with spanner symbol blinks for 10 seconds after the self test cycle of speedometer and continues to glow till the vehicle is serviced and reset. "Service Due" statement will be flashed as a warning.

SERVICE
DUE

Get the vehicle serviced at TVS Motor Company Authorised Main Dealer / Authorised Dealer.

Note

Service reminder indicator lamp works only based on the distance (km) covered by the vehicle. This is only a reminder indicator. Customers are advised to keep track and follow the service schedule.

17. ISG malfunction indicator ()

ISG malfunction indicator will be turned 'ON' when there is a fault in the ISG system.

If the ISG malfunction indicator is glowing continually after the self check cycle of the speedometer, immediately contact the nearest TVS Motor Company Authorised Main Dealer / Authorised Dealer.

Please remember that the 'TVS IntelliGO' and 'iGO Assist' system will not work if the ISG malfunction indicator is 'ON'.

18. Low fuel indication ()

Low fuel indicator blinks when the fuel level is about to reach minimum safe fuel level. It glows continuously when the fuel comes below minimum safe level.

Caution

*Before turning the ignition key to 'ON' position, ensure the availability of adequate fuel in the tank. That is LOW FUEL INDICATION shall not come 'ON', before the start of the vehicle. **To avoid dry run of fuel pump, never run vehicle beyond 5 km, after LOW FUEL INDICATION.***

19. Digital clock / 20. iGO Assist Indication / 21. Tachometer



19. Digital clock

Indicates the time in 12 hour format (AM or PM).

5:06 PM

Note

If the battery is disconnected and reconnected during service. You may need to reset the time as explained in page no "Clock setting" on page 41.

20. iGO Assist Indication

iGO Assist Function enhances the engine's power during sudden Acceleration, thereby reducing the strain on engine and consequently improving its longevity and performance.

This system will be automatically activated when the following conditions are fulfilled:

1. The vehicles battery voltage is more than 12.5 Volts.
2. The engine temperature exceeds approximately 55° C.

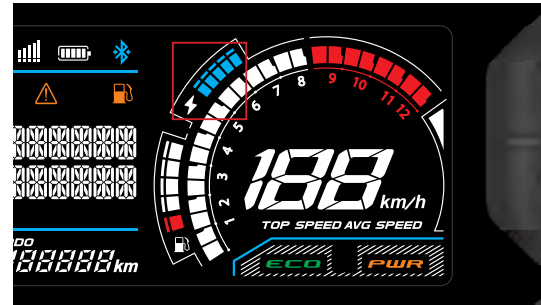

How to Activate the iGO Assist

1. Once iGO Assist is available - by giving sudden throttle acceleration, this iGO Assist can be activated, and it is indicated in speedometer as " iGO READY".
2. iGO Assist can be used approximately for a time of 8 seconds.

How to deactivate from iGO Assist

1. While using the iGO Assist, if the throttle is decelerated or the vehicle speed exceeds 80 kmph - at these conditions, system will get out from iGO Assist and enters into charging period.
2. After using the iGO Assist for 8 seconds, the system will automatically enter charging period.

Once the charging period is completed, iGO Assist will be available and the same will be Indicated in the speedometer.

Note

If any malfunction is displayed in the speedometer, lease visit nearest TVS Motor Company Authorised Main Dealer / Authorised Dealer.

21. Tachometer

The tachometer indicates engine speed, with each bar representing 500 rpm (Revolutions Per Minute) increments and the numerical display showing speed in multiples of 1000 rpm.

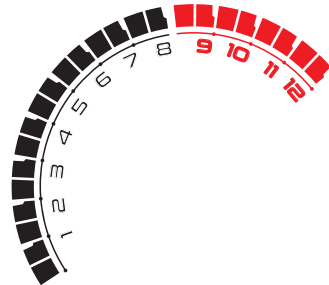

RIDE MODES

There are two ride modes are there in your scooter:

- Street mode
- Race mode

For city drive conditions, Street mode is recommended. For highway drive conditions, for better performance and for powerful ride, Race mode is recommended.

STREET
MODE

RACE
MODE

Note

If there is error in the scooter ie. if the MIL is ON, then it is not possible to change the modes. Similarly, the mode change will not happen if the vehicle speed is greater than 85 kmph. In error condition, by default, it will be in Street mode.

If you are in Street mode at 80 kmph, there will be a recommendation to change to Race mode in the instrument cluster.

MODE AND SET BUTTONS



The 'Mode' (A) and 'Set' (B) buttons are provided to change between various modes and to set the some of the digital display functions of the digital speedometer. The sequence of modes and their selections are explained in detail below.

Short press the 'Mode' button to access the following modes:

1. Trip A
 2. Trip B
1. In 'Trip A' mode, press the 'Mode' button once to enter 'Trip B'.
 2. Press the 'Mode' button once again to change the display to 'TRIP A' mode again.

To reset the 'TRIP A' or 'TRIP B' meter

- Turn 'OFF/ON' the speedometer and the speedometer enters into default BT pairing mode.
- Once the vehicle speeds exceeds 2 km/h, the speedometer exits BT pairing mode and returns to previous 'TRIP A' or 'TRIP B' mode.
- Now press and hold the 'Set' button for a few seconds to reset the respective trip meter.

Else,

- Long press the 'Mode' button and enter into normal display of the speedometer (either 'TRIP A or TRIP B' mode) as explained earlier.
- Now press and hold the 'Set' button for a few seconds to reset the respective trip meter

On long pressing the 'Mode' button, the following modes can be accessed.

1. Street / Race mode stats
1. BT PAIR MODE
2. CLOCK SETTING
3. BRIGHTNESS SET

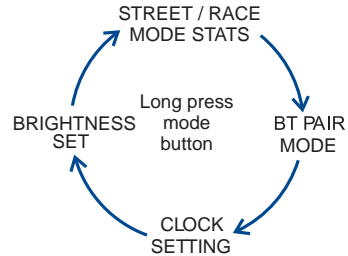

1. Long press the 'Mode' button to enter 'Street / race mode stats' from any mode except BT pair mode.
 - To reset the 'Street / race mode stats' while ensuring the display is in 'Street / race mode stats' mode , press and hold the 'Set' button for a few seconds.

Clock setting

In 'BT pair' mode, long press the 'Mode' button to enter 'Clock setting'.

SET CLOCK

- On entering the clock setting mode, the digital clock starts blinking. Now, press the 'Set' button. On pressing the 'Set' button, the hour digits of the clock starts blinking and enables you to change the hours. Press the 'Mode' button to increase the hours while hour digits are blinking.
- On pressing the 'Set' button again the hours gets set and the minute digits starts blinking.
- Now, press the 'Mode' button to increase the minutes while minute digits are blinking.
- Once again press the 'Set' button so that the minutes of the clock is set and the hours format 'AM' or 'PM' starts blinking.
- Press the 'Mode' button to change the hour format either to 'AM' or 'PM'.
- Press the 'Set' button once again to set clock and long press 'Mode' button to come out of clock setting mode.

4. Press the 'Mode' button once to change the display to 'ODO' mode again.

Note

Above mode changes are possible only when the vehicle is in static condition for safety.

If no input is given for more than 20 secs during clock setting, the digital speedometer comes out of this setting mode automatically.

Brightness set

In 'Clock setting' mode, long press the 'Mode' button to enter 'Brightness set'.

Now press the 'SET' switch to increase / decrease the display screen brightness percentage.

BRIGHTNESS
SET -- 60 %

On each press of the 'SET' switch, the brightness value increases with the increment value of 20% till it reaches the maximum of 100%.

Note

By default, the brightness value is set at 60%. Once the illumination level is altered and after ignition is reset (ON / OFF), it will follow time based brightness.

If the clock is set by mode switch operation and if the illumination is set by Bluetooth mobile application,

From 6:00 AM to 6:00 PM illumination shall be 100%.

From 6:00 PM to 6:00 AM illumination shall be 60%.

If clock is not set by mode switch operation or illumination is not set by Bluetooth mobile application, RLCD brightness value will be default value 60%.

BT PAIRING

On every ignition ON and after welcome animation is completed, the instrument cluster displays its Bluetooth pairing name (unique for each cluster) in information panel.

TVS22A00008
BT MODE

The connected instrument cluster of your TVS NTORQ 125 Race XP can be connected to your Android™ smart phone and iPhone® via Bluetooth® through a **TVS CONNECT** app which can be downloaded from Google Play store and the App Store®.



TVS CONNECT

First time Bluetooth pairing:

To pair your Android smart phone or iPhone with your TVS NTORQ 125 Race XP's connected instrument cluster, via Bluetooth, for the first time, follow the procedure as described below :

1. Switch 'ON' the vehicle.
2. Enter the 'BT PAIR MODE' of connected speedometer as explained earlier.
3. Open the 'TVS CONNECT' app and press the 'CONNECT' icon, while ensuring that the smart phone is near to the vehicle.
4. The app searches for all Bluetooth devices near by and displays the list of devices available.
5. The connected instrument cluster's Bluetooth name is prefixed by TVS and followed by alpha-numeric digits. Ex : 'TVSXXXXXX'. This Bluetooth name can be found in the speedometer dial after turning the ignition 'ON'.
6. Now, select the 'TVSXXXXXX' in the app to initiate the pairing process.

7. On pairing, the connected speedometer displays 'CONNECTION SUCCESSFUL' message for 3 secs and a Bluetooth icon '📶' will be displayed continuously until the pairing condition exits.

CONNECTION
SUCCESSFUL

8. In Addition to this icons, phone's battery level icon, mobile signal strength level (only in android devices), incoming call icon, unread message icon and location icon will be present on the top near clock.

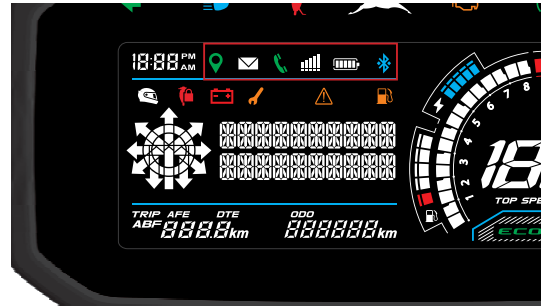

Note

During the course of pairing process, if there is any occurrence of error, the connected speedometer should be turned 'OFF' and 'ON', and the application also need to be restarted.

Please remember that all the smart phones are not compatible for pairing with the TVS NTORQ 125 Race XP's connected speedometer.

During the search of Bluetooth devices in app, if the vehicle's connected speedometer's Bluetooth device ID is not visible, try for one or two more iterations.

Any number of Android smart phones can be auto-paired with the connected speedometer of TVS NTORQ 125 Race XP, but only one at any point of time will be actively connected with the speedometer.

Only one iPhone can be auto-paired with a single connected speedometer at a time. If the user need to connect multiple iPhones with the single speedometer, the previous connected iPhone has to be forgotten by clicking, 'Forget This Device' from Bluetooth settings of the iPhone.

If the vehicle battery is reset or fuse is blown, then 'Forget This Device' from Bluetooth settings.

Steps to 'Forget This Device' in iPhone:

If the user needs to connect multiple iPhones with the single connected speedometer, the previous iPhone has to be forgotten using 'Forget This Device' from Bluetooth settings in the following manner:

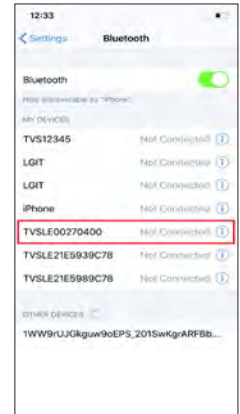
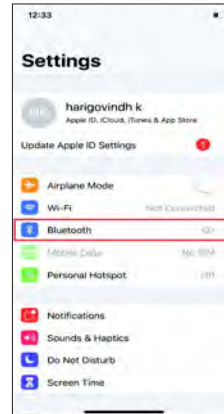

1. In the previous connected iPhone, open the SETTINGS -> BLUETOOTH tab.
2. Select the connected speedometer, which was connected previously.
3. Click on the 'Forget This Device' tab.

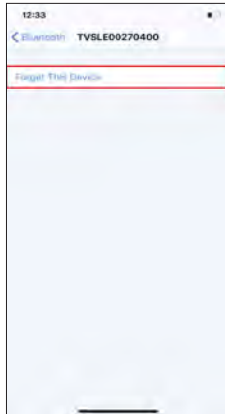

Steps to 'unpair' in Android phones:

Similarly, if the user has any issue in auto pairing the existing paired Android smart phone or to connect multiple Android smart phones with the single instrument cluster, the previous paired Android smart phone has to be unpaired. To unpair an already paired smart phone:

1. In the previous connected Android smart phone, open the SETTINGS -> BLUETOOTH tab.

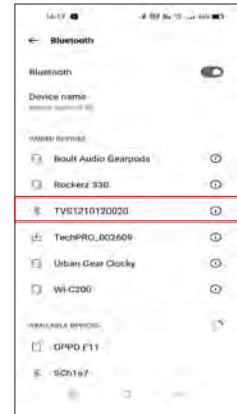
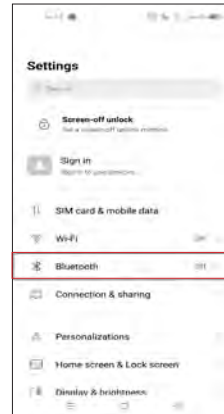

2. Select the speedometer which was connected previously and click on the 'Unpair' tab.



Note

In case multiple SIM cards are used in smart phone, by default, SIM 1's network provider's signal strength is shown in the display of connected speedometer (only in android devices).

Signal strength displayed in the connected speedometer might vary from the display in smart phone as the former is referred from telephonic standards.

Note

If the smart phone enters battery saver mode, auto-pairing might not happen. It takes maximum of five minutes for auto-pairing and it can happen in vehicle running or engine at idling or engine off condition.

Auto-pairing happens only if the application is locked in the RAM in multitasking screen of the smart phone which has customized OS (Ex : MI, Vivo etc.).

In case of Android smart phones with Android OS version above 8.0, for App to work seamlessly, any battery optimization setting to be removed in the TVS Connect App and GPS shall be allowed to run in background in high accuracy mode.

Even if your smart phone's Bluetooth is already paired to other gadgets like smart watch, health band or helmet, the auto-pairing works with your TVS NTORQ 125 Race XP's connected speedometer.

If the application unfortunately stops due to unforeseen circumstances, close and reopen the application and do the manual pairing for the first time, then auto pairing will happen subsequently.

For first time pairing, logout from the app, login again with your login credential and press 'CONNECT' tab.

Auto pairing:

Once the first time pairing is done between vehicle's connected speedometer and your smart phone, the smart phone will automatically connect with the vehicle when the following conditions are met:

1. Vehicle is switched 'ON' and vehicle is near to the smart phone.
2. Smart phone's Bluetooth is turned 'ON'.
3. First time pairing is ensured.
4. In case of iPhone, the 'TVS CONNECT' app should be opened or be opened in background for auto-pairing to happen.

Every time auto-pairing happens, app will open automatically and connect with the connected speedometer. The connected speedometer displays 'CONNECTION SUCCESSFUL' message at the notification area.

CONNECTION
SUCCESSFUL

Once the connected speedometer of your TVS NTORQ 125 Race XP is connected with your smart phone, the connected speedometer displays phone's battery level icon, mobile signal strength level, incoming call icon, unread message icon and location icon will be present on the top near clock.

If your smart phone is disconnected from the vehicle's connected speedometer then, 'Device DISCONNECTED' message will be displayed on the connected speedometer's display.

DEVICE
DISCONNECTED

Incoming call alert display '📞':

After pairing, the connected speedometer will display the incoming call alerts from the smart phone via Bluetooth. Ex. 'CALL FROM TVSM', will be displayed if the contact is stored in the smart phone otherwise number will be displayed. Ex. 'CALL FROM 9999999999'.

CALL FROM
TVSM

CALL FROM
9999999999

The last caller details incase if the caller ID is stored in the memory will be displayed as shown below:

CALLER NAME
TVSM

Incoming SMS alert display '  ': (applicable for iOS)

The connected speedometer's RLCD will display the incoming SMS alerts from the smart phone via Bluetooth. Ex. 'SMS FROM TVSM', will be displayed only if the contact is stored in the smart phone.

SMS FROM
TVSM

Navigation assist:

After pairing, once the navigation option is enabled on the mobile app, the speedometer enters the navigation mode and displays the below message:

NAVIGATION
ASSIST ON

On receipt of the navigation commands from the mobile app, the same will be indicated by the speedometer to the user using the alpha-numeric display as shown below:

 450m
TURN RIGHT

The route suggested by the app is not followed and alternate route is taken, re-routing will be done by the app and the same will be displayed by connected speedometer as shown:

RE-ROUTING

Once you reach your desired destination, the connected speedometer displays arrival message as shown below:

YOU ARRIVED

Phone battery low indication:

If the connected smart phone's battery charge status is lesser than 10% then, the speedometer displays the below warning message:

PHONE LOW
BATTERY

Alerts messages

Fuel sensor error message:

If there is any malfunction in the fuel sensor 'CHECK FUEL SENSOR' error in the connected speedometer display.

Speed sensor error message:

If there is any malfunction in the speedo sensor 'CHECK SPEED SENSOR' error in the connected speedometer display.

Service reminder:

Service reminder '🔑' turns 'ON' whenever the service is due and till the reminder is reset.

Low battery indicator:

An icon with battery symbol '🔋' glows whenever the battery charge is too low.

iGO assist indicator:

TVS NTORQ 125 Race XP is equipped with lightweight engine with iGO Assist. This feature delivers a boost in acceleration from a standstill and during overtaking scenario.

This system will be automatically activated when the following conditions are fulfilled:

1. The vehicles battery voltage is more than 12.5 Volts.
2. The engine temperature exceeds approximately 55 deg C.
3. There is no error in the vehicle

Once these conditions are met, the speedometer displays " **iGO** " and with sudden throttle

READY

acceleration, assist will be activated.

Assist can be used approximately for a time period of 8 seconds. After assist activation, the vehicle enters into charging state for few minutes. Once battery is charged, once again "iGO READY" indication will be displayed in the speedometer.

TVS CONNECT APP



Dedicated smart phone app is available in the Google Play and the Apple store for your 'TVS Ntorq' and it can be installed in your Android and Apple smart phones. To access the features of your TVS NTORQ 125 Race XP's connected speedometer like:

- Incoming call alerts, SMS alerts, number of missed call alert, etc. in the connected speedometer.
- To know the battery status and signal strength (only in android devices) of your smart phone in connected speedometer.
- Fuel status, distance to empty, live tracking (speed & mileage of current ride) details in App.
- To enable / disable 'Do Not Disturb' mode during the ride (applicable only for Android smart phones).
- To enable / disable 'High Speed Alert' during ride.
- To send navigational assist instructions inputs to the connected speedometer from your smart phone.

- To save the last traveled route.
- To locate the last parked location of your TVS NTORQ 125 Race XP.
- To generate, store and share Ride reports.
- To sync the connected speedometer clock with smart phone clock.

This dedicated mobile app of your TVS NTORQ 125 Race XP can be downloaded from the Google Play store and the App Store® by searching the key word '**TVS CONNECT**' else by scanning the below QR code.



Android



iOS

How to login

On opening the **TVS CONNECT** App the following introductory screen will be displayed.



Click on the 'Login' tab provided at the top of the screen to begin a login process.

On entering the login screen you will be prompted for your registered mobile number entry. Enter the mobile number and press 'Continue' tab to proceed further.

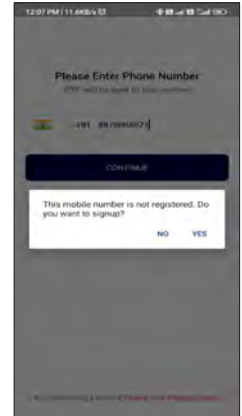

Now, an OTP verification screen will get open. Key-in or copy & paste the OTP received from TVSM to login.

Note

During login process, will be prompted for various permissions by the App. Provide necessary permission to the app to work seamlessly.

An logging in successfully the default vehicle screen opens as shown below with various informations.

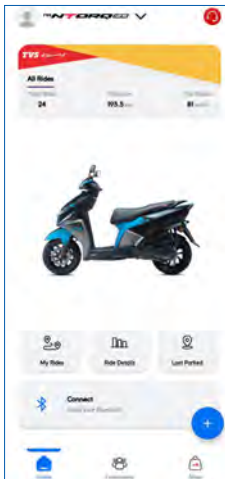

Note

Refer App help for complete details.

Onboarding TVS Vehicle

You can onboard your TVS vehicle into the App by following the procedure given below:

- Scroll down the initial screen and click on the 'Onboard TVS Vehicle or Accessory' tab and select the 'Onboard a TVS Vehicle' option.

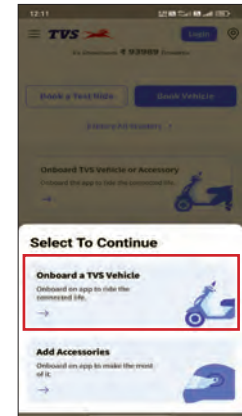
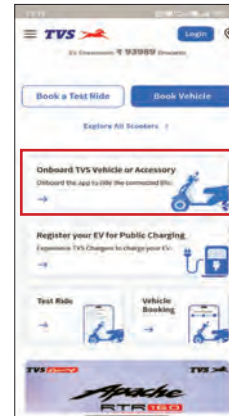

- On selecting this option, a screen with options of adding your vehicle or accessories will get open. Select the 'Add Vehicle by VIN' tab of the screen.
- Now, Another screen gets open with the VIN number and Invoice date or Engine/Motor number entering options.
- Key-in the necessary data to add the required vehicle and press the 'Add' button at the bottom of the screen.

Note

You can get the number by chatting with us or by E-mailing to us or by calling us.

After completing the trip, whenever the vehicle is switched ON again, TVS Connect app will not connect automatically. Click the 'Connect' button of TVS connect app to connect with cluster.



Terms & Conditions

- SmartXonnect feature is now enhanced with Voice Assistance capability. This will enable the user to control certain characteristics of the vehicle in a safe manner.
- Customers can use the voice commands listed as part of the voice assistance feature to improve their riding experience.
- SmartXonnect Voice Assistance is intended to minimize the use of Mobile phones while riding, in turn providing an exciting experience with the Bluetooth enabled system. We recommend users to take caution when providing voice commands.
- SmartXonnect Voice Assistance can be experienced with the help of following entities - TVS Connect App, TVS NTORQ Race Edition XP and a suitable Bluetooth accessory having a microphone and speaker. Users are recommended to wear certified helmets always while riding.
- In cases where customer uses a Bluetooth neckband or headset, it is recommended to always wear helmet.
- The Bluetooth® word mark and logos are registered trademarks owned by Bluetooth SIG, Inc., and any use of such marks by TVS Motor Company Limited., is under license.
- Customers must always be cautious of the surroundings when using the SmartXonnect Voice Assist feature, especially while crossing intersections, in traffic, etc. Customers must always observe the roadway, signs, and signals carefully. Lack of attention can cause serious injury or loss of life. TVSM is not liable for any such mishaps.
- Customers must always obey traffic laws while riding. TVSM is not liable for any penalty caused due to user's lack of caution in obeying traffic laws
- Costs of network communication and communication equipment necessary for the use of SmartXonnect voice assist feature shall be borne by the user himself/herself.
- Some smartphones may not be compatible with the SmartXonnect Voice Assistance feature. We shall not be liable if there is delayed response from the voice assistance feature due to poor internet connection or the phone's performance limitations.

- Use of mobile phones while riding is not safe and is prohibited as per Motor Vehicle law and rules as framed by central / state governments. Hence, Customers should not use the mobile phone while riding. We shall not be liable for any penalties, damages for any violation or trouble in the use of smartphone while riding.
- Bluetooth hands free devices are not included as part of the package
- SmartXonnect Voice assist feature also provides display information in the cluster. Users are advised to verify the voice guidance and information in the meter provided by the system carefully. If you are unsure, proceed with caution. Always use your own good judgement, and obey traffic laws while riding
- Changes in operating systems, hardware, software, and other technology integral to providing SmartXonnect Voice assistance feature, as well as new or revised governmental regulations, may result in a decrease or cessation of SmartXonnect Voice assist functionality and services. TVSM cannot and does not provide any warranty or guarantee of future SmartXonnect Voice assist performance or functionality.

LED HEAD LAMP CUM POSITION LAMP WITH ALL TIME HEAD LAMP ON (AHO)

TVS NTORQ 125 Race XP comes with a LED head lamp cum position lamp. Position LED which glows automatically once the ignition is turned 'ON' and LED head lamp glows automatically when the engine is started, Only the head lamp beam (high/low) can be controlled by pressing the high/low beam switch.



KICK STARTER LEVER*

The kick starter lever is located on the left side of the vehicle. To start the vehicle, park the vehicle on centre stand and keep the ignition in 'ON' condition. Move the lever extension (A) outwards and keep your foot on the lever extension. **Kick the lever from top and stroke to bottom with rapid motion.** Push back the lever extension to its original position once the vehicle is started.

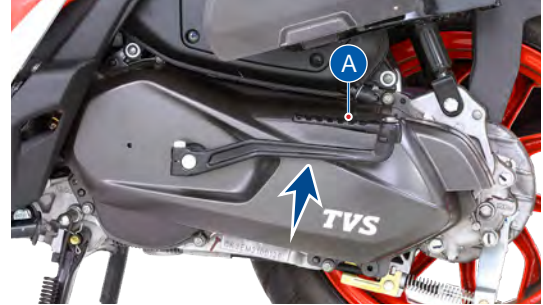

Caution

Put the vehicle on center stand before applying the kick starter lever to avoid kick lever hitting with center stand.

* Optional accessory will be charged extra

FUEL TANK# CAP

Fuel tank is located at the rear end of the vehicle below the pillion holder.

To open the fuel tank cap, insert the control key into the 'seat cum fuel tank cap lock' and turn it in anti-clockwise direction. The fuel tank cap opens automatically. To close the cap, gently press the cap back to its position and ensure locking of the cap by hearing '**click**' sound.



The fuel tank is not a measuring instrument and the capacity of the fuel tank may slightly vary from the indicated capacity.

Warning

Never refill fuel near open flame. Do not smoke while refueling. Do not use cell phones while refueling.

Caution

Ensure that the fuel gun is inserted fully in the tank neck while refueling.

Whenever refueling, fill upto the bottom of neck portion (insert level) of the fuel tank. Filling above the neck may result in improper breathing of fuel tank and seepage of fuel.

While refueling, avoid spillage of petrol on the tyre. If fuel spills on tyre, the tyre will loose its grip on the road. Ensure to close fuel tank cap without fail to avoid fuel spillage.

EFFORTLESS E-Z CENTRE STAND

TVS NTORQ 125 Race XP is equipped with a effortless centre stand. The centre stand (1) has a pivoted flexible spring loaded lever arm (stand extension) (2) to increase the lever ratio, which enables parking on centre stand effortlessly and very conveniently.



To place the vehicle on centre stand, hold the handle bar left grip with left hand, place your foot firmly on the centre stand extension (2) while ensuring that both the stand shoes are touching the ground, press the stand extension.

Warning

Always retract the side stand to its full up position before moving the vehicle. Else, the vehicle will not get start.

Caution

Never sit on vehicle when it is supported by stands. Always park the vehicle on a flat, firm surface.

SIDE STAND (mandatory accessory)#



Side stand can be operated by sitting on vehicle with your left foot by pushing it away from the vehicle till it stops.

Warning

Always release the side stand to its full up position before starting the vehicle. Else the vehicle will not get start.

Mandatory accessory will be charged extra

TOOL KIT AND FIRST AID KIT

To assist you in performing certain aspects of periodic maintenance and emergency repairs, a tool kit is supplied along with the vehicle and it is located below the seat base. To access the tool kit, insert the control key into seat lock and rotate it in clockwise direction. Lift and open the seat.

The tool kit consists one number each of the following. Ensure the contents of the tool kit.

1. 10x12 mm spanner
2. Combination screw driver bit
3. Screw driver handle
4. Tool bag



 **Caution**

It is recommended to use the tool kit in case of any emergency only. It is always advisable to take your vehicle to TVS Motor Company Authorised Main Dealer / Authorised Dealer.

UTILITY BOX

Utility box is located below the seat. Lift the seat by unlocking the seat lock as explained in the previous page, to access the utility box.



 **Warning**

Operating the TVS NTORQ 125 Race XP overloaded will hamper riding stability and may lead to loss of control. Hence, it is advisable to carry the recommended amount of load only.

 **Caution**

Utility box can be used to carry a load of 10 kg maximum.

Do not carry perishable items inside the utility box. It is not fully sealed. Do not allow / spray water to get inside the utility box. Take care not to spill petrol or oil into the utility box.

Do not keep heat-sensitive items inside as it may get hot on long rides.

Do not keep valuable items inside the utility box when leaving the vehicle unattended.

HELMET HOOKS

Two helmet hooks are provided under the seat assembly at front end near the seat hinge to secure your helmet. Open the seat assembly (refer page no. 60) to access the helmet hooks. Hook the helmet strap in the helmet hook properly and close the seat assembly.



BAG HOOKS

There are two bag hooks provided with your scooter to carry light luggage like carry bags weighing upto 3 kg. One hook is located below handle bar on the rear panel.

Just pull out the hook from the top (A) to hang your luggage. Push back the hook once it is free.

Similarly, the other one is located on the cover front below front end of the seat assembly. Pull out the hook from its position. Open the top lid and hang your cargos. Lid will get close automatically. Push back the hook to its original position once it is free.

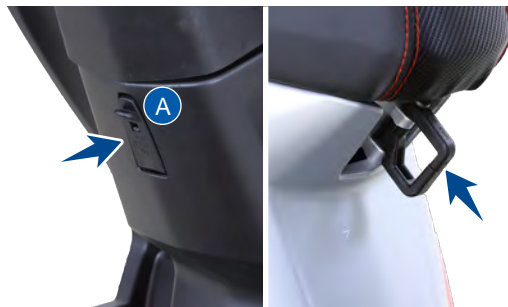

Caution

Care should be taken not to attach the luggage which hangs out of your scooter. Please note that the luggage attached to your scooter should not interfere your feet movement.

SMART PHONE CHARGER#

All new smart phone charger has been provided in the utility box of your vehicle (refer page no. 61). Please follow the guidelines mentioned below for using it properly:

DO's

1. Ensure that no water enters into the unit, by closing the USB flap properly.
2. Use the USB, if approved standard USB cable used for charging mobile.
3. Do make sure the flap (A) is not damaged while opening / inserting the USB cable.

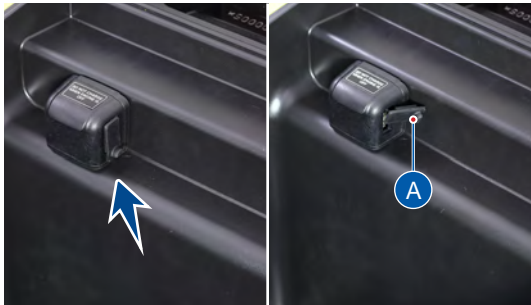

DON'Ts

1. Do not leave the USB charging flap open / partially closed.
2. Do not attempt to use / charge any other device, other than mobile phones. Only one mobile phone should be charged at a given time.
3. Do not try to force the USB connector in, check whether it is inserted in the appropriate direction, to prevent the damage to the charger.
4. Do not charge your mobile when engine is off.



Caution

The charging time of the mobile may vary, depending on the mobile's battery state of charge. The rubber flap in the unit has been designed to prevent water entry and is not replaceable. No warranty for charger in case of rubber flap cut.

The smart phone charger will be a part of Disc Brake variant. For Drum Brake variant the same need to be purchased and fitted on the scooter.

PRE RIDE INSPECTION

Check the following items before riding

ITEM	WHAT TO CHECK FOR
Engine oil	Availability of oil upto the level (page no. 78)
Transmission oil	Availability of oil upto the level (page no. 79)
Fuel	Enough fuel for the planned distance of running
Tyres	Correct pressure (page no. 83) Adequate tread depth / No cracks or cuts.
Battery	Proper working of electric starter, horn, fuel gauge, pass by, brake lamp and turn signal lamps. Battery voltage (page no. 73)
Lighting	Proper working of head lamp high / low beam, DRL, high beam indicator, position lamp, connected instrument cluster back illumination, tail lamp and number plate lamp.
Steering	Smooth movement / no play or looseness
Throttle	Correct free play of cable / smooth operation
Brakes	Correct front / rear brake lever play (page no. 80) Availability of brake fluid and proper working of brake (page no. 80)
Wheels	Free rotation of front and rear wheels

STARTING THE ENGINE

Ensure availability of adequate fuel in the fuel tank. Insert the control key into the ignition cum steering lock and turn it to the 'ON' position. In side stand retracted condition, apply any one of the brake and press the electric starter switch to start electrically or kick start.

Setting the vehicle in motion

1. Twist the throttle grip slowly towards you and simultaneously release the brake lever gently and smoothly. The vehicle will start moving forward.
2. As the vehicle picks up speed, increase the throttle slowly.



Caution

Do not keep the engine in idling rpm for long and do not open excessive throttle when the vehicle is on side stand or off stand with brakes applied condition. It leads to overheating of engine and damage to the internal components.



Warning

Do not raise the throttle rapidly so the vehicle will move forward suddenly and lead to loss of control.

Stopping and parking

1. Close the throttle completely and apply both the brakes simultaneously.
2. Turn the ignition 'OFF'.
3. Park the vehicle on a firm, flat surface.
4. Lock the steering and take out the control key.



Warning

Reduce speed to a safe limit before turning / cornering. Do not apply brake while turning / cornering.

FUEL RECOMMENDATION

Use only BS VI petrol with minimum RON 98.

BS VI petrol containing upto 20% of ethanol by volume can be used.

Higher ethanol content in petrol can lead to

- degrade plastic and rubber components of fuel system and vehicle parts
- cause corrosion damage to metal parts like fuel tank, etc
- result in startability & drivability issues
- decrease fuel economy

Ethanol absorbs water very easily, resulting fuel separation. Extra care shall be taken to prevent moisture entry into fuel tank while filling ethanol blended petrol and water washing of vehicle.

Painted parts (viz. panels, covers) shall not come in contact with ethanol blended fuels. Manufacturer is not responsible for any warranty issues that results from using ethanol blend in excess of 20% by volume in petrol.

In case of any abnormalities observed due to use of ethanol blended fuels, customers are advised to use a different fuel station / brand for standard E20 fuel or contact authorised service centres.

Caution

Never mix oil in petrol in the fuel tank. Always fill fuel from the reputed and reliable fuel stations.

CHECKS AND TIPS FOR IMPROVING FUEL ECONOMY

Regular checks

Carry out the periodic maintenance checks as specified in this manual (page no. 68).

Regular maintenance checks will save fuel and ensure trouble-free, enjoyable and safe riding besides keeping environment clean.

Spark plug

A dirty or defective spark plug leads to wastage of fuel due to incomplete combustion. Clean and adjust the spark plug only if necessary. **Replace the spark plug every 12000 kms (1 year). Always use recommended spark plug only.**

Air cleaner element

A dirty air cleaner element restricts airflow and increases fuel consumption. **Replace the element every 12000 kms.**

Since foam and paper type air filter element is used in your scooter, it is recommended to clean the foam filter element using mild compressed air from inside **every 3000 kms.** Replace the filters incase found any abnormalities.

Engine oil and Transmission oil

Dirty or less engine oil increases the friction between various parts of the engine and reduces the engine life, thereby increases the fuel consumption.

Running with low transmission oil will cause damage to the gears and bearings.

Regularly inspect the engine oil and the transmission oil for correct level and top-up if necessary. Get it replaced at regular intervals as per the maintenance schedule.

Fuel leak

Inspect and arrest fuel leaks if any from tank and fuel lines. Loss of fuel due to leak may drain the fuel tank completely.

Evaporation

Vehicle parked in the hot sun leads to wastage of fuel through evaporation. Also, lower fuel levels in the tank will have increased evaporation and condensation of moisture inside.

Ensure to close fuel tank cap after every filling. If the fuel tank cap kept open for long time, it leads to safety and fuel loss.

Tyres

Low tyre pressure has adverse effect on the vehicle. The **drag on the vehicle** increases resulting decreased fuel economy. Further more, handling may be adversely affected.

Inspect the tyre pressure regularly (weekly) and inflate it to the recommended pressure (refer page no. 83). Never use tyres which are worn beyond the permissible limit.

Wheel freeness

Inspect and ensure the wheel freeness by rotating the wheel at least once in a week to avoid wastage of fuel.

Avoid unnecessary idling

While waiting for someone or stopping in signals for long time, if the engine is kept running at idle speed, it causes unnecessary wastage of fuel.

Avoid frequent braking

Anticipate corners and slopes as well as the traffic conditions. **Unnecessary and frequent braking will reduce the fuel economy. Never accelerate and apply brake simultaneously.** It leads clutch shoes wear and wastage of fuel.

Note

The on-road mileage of TVS NTORQ 125 Race XP is dependent on several factors like road condition, quality of fuel, riding speed, operation of clutch and brake, tyre inflation, maintenance / timely servicing of vehicle, load etc. and hence will differ from the mileage given under standard test conditions such as made in recognised institutes.

MAINTENANCE SCHEDULE

The maintenance schedule indicates the intervals between periodic services. At the end of each interval, be sure to inspect, check, replace, adjust, lubricate and service as instructed. If the maintenance is not done periodically, it will result in rapid wear and severe damage to the vehicle. If the vehicle is used under high stress conditions such as continuous full throttle operation or is used / operated in dusty area, certain jobs should be performed more often to ensure reliability of the vehicle. Cylinder head, steering components, suspension and wheel components etc., are key items and require very special and careful servicing. TVS Motor Company Limited strongly recommends that the jobs as per the maintenance schedule be performed by your TVS Motor Company Authorised Main Dealer / Authorised Dealer.

Periodic inspections may reveal one or more parts that may need replacement. Whenever replacing parts on TVS NTORQ 125 Race XP, it is recommended that you use only the TVS Motor Company Genuine parts.



Caution

Proper running-in and maintenance are mandatory for making certain that your vehicle is reliable and gives optimum performance at all times. Make sure that the periodic maintenance is performed thoroughly in accordance with the instructions given in this user's manual.

In more dusty areas, the air filter elements required early inspection than the mentioned kilometers to avoid costly damages to the engine. If the elements are found with excessive dirt / clogged with dust, clean foam and paper elements using mild compressed air from inside. Replace the filters incase found any abnormalities.



PERIODIC MAINTENANCE SCHEDULE (months or km whichever occurs earlier)

Item	Service km	In free service				After free service		Remarks
		1st 500 - 750 2 months	2nd 2500 - 3000 4 months	3rd 5000 - 6000 8 months	4th 8500 - 9000 12 months	Every 3000 km 4 months	Every 6000 km 8 months	
Engine oil		R	I & T	R	I & T	I & T	R	
Oil filter (strainer)		C	-	C	-	-	C	
Transmission oil		R	I & T	R	I & T	I & T	R	
Spark plug		C & A	-	-	-	-	-	Inspect, Clean and adjust if required, Replace every 12000 km
Air cleaner (foam element)		I & C	I & C	I & C	I & C	I & C	-	Replace every 12000 km (as a set)
Air cleaner (paper element)		I	I	I	I	I	-	Replace every 12000 km (as a set)
Air cleaner oil collection tubes		-	I & DR	I & DR	I & DR	I & DR	-	Drain oil if necessary
CVT filter element ¹		-	-	I & C	-	-	I & C	Replace every 12000 km
Tappet clearance		I & A	-	I & A	-	-	I & A	Inspect for any noise / starting trouble and adjust if required
Drive belt and CVT rollers		-	-	-	-	-	-	Replace every 24000 km
Cover variator ²		-	-	I, C & L	-	-	I, C & L	
Clutch shoe		-	-	-	-	-	-	Replace every 24000 km
Hose fuel		-	-	-	-	-	-	Inspect every service after four years, replace if required.
Front and rear suspension		I	I	I	I	I	-	Inspect for proper functioning

¹ Inspect for damage

² Clean the cover with air. Lubricate kick starter with Bechem grease

Contd...

Item	Service km	In free service				After free service		Remarks
		1st 500 - 750 2 months	2nd 2500 - 3000 4 months	3rd 5000 - 6000 8 months	4th 8500 - 9000 12 months	Every 3000 km 4 months	Every 6000 km 8 months	
All control cables ³		I, A & L	I, A & L	I, A & L	I, A & L	I, A & L	-	
Throttle grip		-	-	L	-	-	L	Lubricate using grease
Steering smooth operation / play		I & A	-	-	-	-	-	C, L & A with fresh grease every 12000 km
Front fork oil		-	-	-	-	-	-	Replace every 24000 km
All fasteners		I & TI	I & TI	I & TI	I & TI	I & TI	-	
All bulbs, horn and switches		I	I	I	I	I	-	Inspect for proper functioning
Head lamp beam		I & A	I & A	I & A	I & A	I & A	-	
Battery voltage ⁴		I	I	I	I	I	-	
Brake effectiveness / play		I & A	I & A	I & A	I & A	I & A	-	Refer page No. 58 & 61 for details
Rear brake cam		-	-	C & L	-	-	C & L	Lubricate using grease
Brake pad wear		I	I	I	I	I	-	Replace if necessary
Brake fluid ⁵		I & T	I & T	I & T	I & T	I & T	-	
Brake hose		I	I	I	I	I	-	Replace every three years
Master cylinder cups		-	-	-	-	-	-	Replace every 21000 km
Disc brake SBS cable play ⁶		I	I	I	I	I	-	Inspect for brake levers rattling

³ Inspect for proper operation and adjust play. Lubricate ends using grease ⁴ Recharge if necessary with MF battery charger

⁵ Replace every 21000 km or 2 years whichever occurs earlier

⁶ Adjust if rattling play is observed in both the brake levers

Cont ...

Item	Service km Period from the date of sale	In free service				After free service		Remarks
		1st 500 - 750 2 months	2nd 2500 - 3000 4 months	3rd 5000 - 6000 8 months	4th 8500 - 9000 12 months	Every 3000 km 4 months	Every 6000 km 8 months	
Wheel freeness		I	I	I	I	I	-	
Front wheel bearing		-	-	-	-	-	-	Lubricate using grease every 12000 km
Tyre pressure at cold condition		I & S	I & S	I & S	I & S	I & S	-	
Malfunction codes		I	I	I	I	I	-	Check and resolve the errors using diagnostic tool if the lamp is ON even after starting the engine
Evaporative emission control system		I	I	I	I	I	-	Check for intactness of hoses and canister
Fuel tank assembly**		I & C	I & C	I & C	I & C	I & C	-	
Centre / side stand pivot		L	L	L	L	L	-	Lubricate using TRU4 oil
Kick starter pedal pivot		L	L	L	L	L	-	Lubricate using TRU4 oil

R - Replace; I - Inspect; T - Top up; C - Clean; A - Adjust; DR - Drain; L - Lubricate; TI - Tighten; S - Set

** Check for abnormal vehicle jerk / noise while opening the cap / leak. If found any, contact TVS Motor Company Authorised Main Dealer or Authorised Dealer.

RECOMMENDED LUBRICANTS

APPLICATION	QTY	MANUFACTURER	BRAND
Engine oil	880 ml (during regular service) 930 ml (incase of disassembly)	TVS Motor Company	TVS TRU4 SKUUTA oil (SAE 10W30 API-SL, JASO MB)
Transmission oil	120 ml (during regular service) 130 ml (incase of disassembly)	-do-	-do-
Front fork oil	91 ± 1 cc / leg	IOC / HPCL	Gabriel Premium front fork oil
Disc brake fluid	-	TVS Girling	DOT 3 / DOT 4
Grease	-	Bharat petroleum IOC Bechem Kluber Lubrication	MP Grease no. 3 Servo Gem no. 3 Bechem premium 3 Kluber Centoplex 2

SELF - MAINTENANCE PROCEDURES

MAINTENANCE FREE (MF) Battery

Battery is located at the front side of vehicle inside the front panel. The front panel must be removed to access the battery in the following manner:

1. Remove the front panel mounting screws.
2. Gently pull out the front panel by dislocating its lugs.
3. Reassemble the parts in the reverse order of dismantling.

Since the maintenance free battery is fitted on your vehicle it is not necessary to top-up with the distilled water.



But to ensure the battery performance and long life, follow the steps given below:

1. Check the battery voltage as per the schedule. If the voltage is less than 12.4 volts, charge the battery using **recommended MF battery charger** at TVS Motor Company Authorised Main Dealer / Authorised Dealer.
2. Do not add any additional electrical accessories other than recommended by TVS Motor Company Limited.
3. It is recommended to remove the negative (-) terminal first and then the positive terminal (+). Similarly, while connecting connect the negative terminal (-) first and then the positive terminal (+).



4. While connecting the terminals observe the correct polarity. Connect the red wire to the positive (+) terminal and the black wire to the negative terminal (-) of the battery.
5. Petroleum jelly must be applied at terminals to prevent it from corrosion.

Incase of any abnormality or for removal of battery from the vehicle, contact TVS Motor Company Authorised Main Dealer / Authorised Dealer.

Caution

Never check the battery charge by shorting the terminals. Always connect the positive terminal first (red wire) and then negative (black wire) to avoid sparking.

The inversion of the battery wires can damage the battery and the recharging system. Always connect the positive then negative to avoid sparking.

* To be done by skilled personnel

Recommendations to maintain battery health during prolonged parking conditions

While your vehicle is parked for prolonged duration, battery continues to discharge and if left unattended can get completely discharged. It is recommended to ride the vehicle for minimum 60 km every week to keep the battery in healthy condition This could be at a stretch in one ride or several rides during the week.

The vehicle speed will vary during the ride but an average speed of minimum 30 kmph will be helpful to ensure proper battery charging. Use kick-starting, if available, to conserve battery charge during such period. This is only a recommendation to maintain battery charge and regular service schedules must be followed to maintain your vehicle in good running condition.

The following is recommendations to users regarding battery maintenance before, during and after long storage of battery:

1. Before Storage

- a. Store the battery only after fully charging it
- b. Battery fuse to be disconnected and stored safely. This will reduce the sleep mode current and hence enhance storage life of battery.*

- c. Alternatively, battery connecting wires (positive and negative wires) can be disconnected and fasteners can be secured with battery terminals.*

2. During Storage

- a. Store it at room temperature or lower.
- b. Store the vehicle in the shade and protected from rain and cover the vehicle to prevent rodents from entering and damaging the wires.

3. After Storage

- a. Connect the wires and fuse, if disconnected earlier, with ignition switch in OFF position*
- b. Start the vehicle by kick starting.

(Above recommendations do not consider storage effects on other systems such as induction and fuel systems and wheels)

Periodic Maintenance of Batteries:

- Keep top of battery clean
- Check cables, clamps, and case for obvious damage or loose connections
- Clean terminals and connectors as necessary
- Recharge battery if voltage is below 12.4 Volts.

* To be done by skilled personnel

- Valve Regulate Lead Acid (VRLA) / Lead Acid batteries are prone to water damage. Any water entry, through vents or otherwise; will result in irreparable damage to the battery or the vehicle.

Warning

Battery develop explosive gases. Keep it away from heat sources. If charging is required the battery must be charged in well ventilated area.

Unusable battery must be disposed in environment friendly manner. Do not discard it with household thrash. Handover the battery to the battery dealers or to a recycle center that accept used battery.

Caution

Never operate the vehicle with discharged battery as it may damage electrical components.

FUSE

Non-working of electrical systems may be due to safety fuse failure. Short circuit or overload in the electrical system are the main causes for fuse failure. There is a fuse case containing three blade type fuses (15A x 1 and 10A x 2) located near the battery. Follow the procedure given below for inspecting and replacing the fuse.

1. Turn 'OFF' the ignition.
2. Remove the front panel as explained earlier.
3. Take out the fuse case from the battery holder.
4. Open the fuse case and pull out the fuse.



Good Fuse

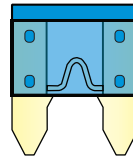

Blown Fuse

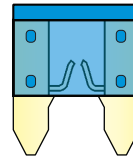

5. Inspect the fuse for failure. If found defective Replace the blown fuse with a new (extra fuses are provided in the wiring harness itself in a pouch).
6. Close and refit the fuse case back to its position.
7. Turn 'ON' the ignition lock and check for proper functioning of the electrical systems. In case the fuse fails again, consult the nearest TVS Motor Company Authorised Main Dealer / Authorised Dealer.

Caution

Do not use vehicle by shorting the wires without fuse. This may result in overheating of electrical items / wiring and may result in fire of vehicle.

Do not use fuse of higher amperage than specified for the safety of electrical system.

SPARK PLUG

To access the spark plug, the cover front has to be removed. Follow the bellow procedure to remove the cover front.

1. Remove the bottom mounting screws (A) of cover front.
2. Open the seat and remove the top mounting screws (B) from both the sides of cover front.
3. Gently pull out the cover front by dislocating its lugs.
4. Clean the dust and mud around the spark plug mounting to avoid falling inside the cylinder.

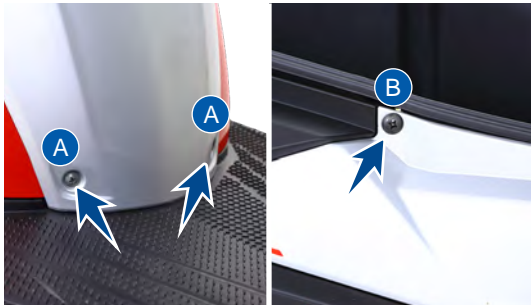

5. Pull out the suppressor cap from spark plug.
Using the spark plug spanner, remove the spark plug.

A spark plug with heavy carbon deposits will not produce strong sparks. Hence, only if necessary, clean the carbon deposits from the spark plug with a small wire brush or spark plug cleaning tool.

Inspect the spark plug electrodes (A) and (B) for any corrosion. If found any replace the spark plug with new. Visually inspect the spark plug gap. The gap should be **0.9 ~ 1.0 mm**. If the gap is found to be more than the limit, replace the spark plug with a new one.

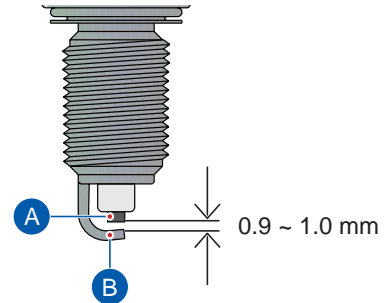

After cleaning and inspecting the gap, reinstall the spark plug and tighten by hand to avoid cross threading. Finally tighten using spark plug spanner. Do not over tight or cross thread the spark plug.

Caution

Always use only recommended make and type of spark plug. Replace spark plug every 12000 km.

Don't remove the spark plug when the engine is hot. Cover the spark plug hole with a cloth when the plug is removed to prevent entry of dust / water.

Do not try to adjust the spark plug as it may damage the plug. Replace the plug if the gap is found more.

It is advisable to tighten the new spark plug by hand till the end, using plug spanner tighten by 1/4 turn. Then loosen the plug by 1/8 turn and re-tighten using plug spanner.

ENGINE OIL LEVEL

Check the engine oil level periodically.

1. Place the vehicle on centre stand on a flat surface. Wipe-off the surroundings of gauge oil level.
2. Remove the gauge and wipe it clean.
3. Fix the gauge back to its mounting hole. Do not thread in.
4. Take out the gauge and check the oil level. The level should be between minimum and maximum level marks of the gauge (shown in the figure).
5. If the oil is less than the minimum level, add 'TVS TRU4 SKUUTA oil (SAE 10W30 API-SL, JASO MB)' upto the maximum level mark.



6. Wipe out the oil traces with a clean cloth to prevent dust accumulation.
7. Assemble back the gauge oil level.

 **Caution**

If the vehicle is driven with less engine oil, the engine components will be severely damaged.

Check the oil level as per the schedule to avoid costly damage. Do not fill excess oil may cause oil leak. Always use 'TVS TRU4 SKUUTA oil only (SAE 10W30 API-SL, JASO MB)'.

TRANSMISSION OIL - LEVEL

Check the transmission oil level periodically.

1. Place the vehicle on centre stand on a flat surface.
2. Wipe-off the surroundings of oil level screw.
3. Remove the transmission oil level screw along with a gasket from the rear end of crankcase L.
4. Check for the flow of oil from oil level hole.
5. If the level is less (if there is no oil flow), top-up with 'TVS TRU4 SKUUTA oil (SAE 10W30 API-SL, JASO MB)' till the oil just starts to flow out from the oil level hole.



6. Wipe out the oil traces with a clean cloth to prevent dust accumulation.
7. Replace the fiber washer while reassembling the oil level screw.

 **Caution**

If the vehicle is driven with less transmission oil, the transmission components of engine will be severely damaged.

Check the oil level as per the schedule to avoid costly damage. Do not fill excess oil may cause oil leak. Always use 'TVS TRU4 SKUUTA oil only (SAE 10W30 API-SL, JASO MB)'.

BRAKES

Front brake

You can observe a master cylinder (1) right side of the handle bar under the head lamp housing.

A caliper assembly (2) fitted to the fork leg L, a disc (3) on the front wheel and a high pressure hose (4) connecting the master cylinder and the caliper assembly.

1. Check the master cylinder brake fluid level through the view piece glass (A).
2. The brake fluid level always should be above the 'LOWER' mark (B) provided on the view piece glass of the master cylinder when the cylinder is parallel to ground.



3. If the brake fluid level is below the mark or while applying brake if you feel the brake is more spongy or ineffective due to air entry, contact TVS Motor Company Authorised Main Dealer or Authorised Dealer for topping-up the brake fluid, air bleeding and other brake related inspections.

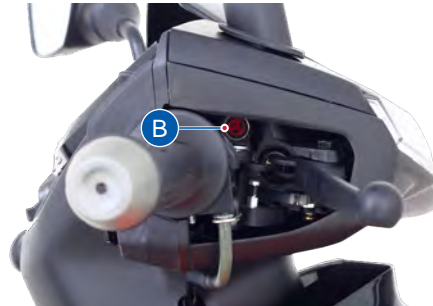

Caution

Master cylinder brake fluid level must be checked only when the master cylinder is parallel to the ground.

Brake pad wear indicator (Disc brake)

Check for the wear of brake pads visually. If the brake pads wear is found beyond the wear indicator groove as shown in the figure, replace the brake pads as a set with a new one.

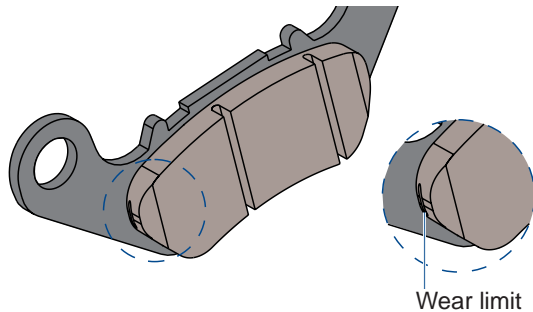

Caution

Replace the brake pads as a set, if the wear indicator shows beyond the wear limit.

Warning

Disc brake SBS cable need to be adjusted incase if rattling is found in both brake levers.

Rear brake (Drum brake)

1. Measure the free play of the rear brake lever at the lever end as shown in the figure.
2. Free play of brake lever before the engagement of brake should be between 10 ~ 15 mm.
3. If the measured distance is more than the limit, adjust the nut provided at the rear wheel end to obtain the correct play.

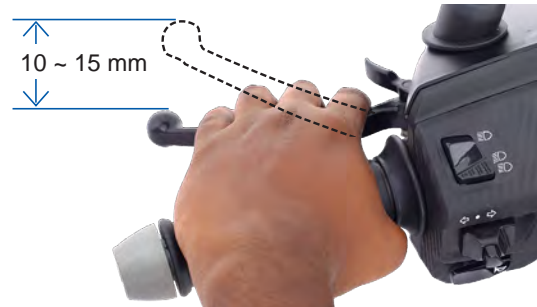

Warning

Check front brake (drum brake type) and rear brake play periodically. However the brake play needs to be adjusted more frequently depending upon the usage.

- Turn the adjuster nut in clockwise direction for reducing free play or in anti-clockwise direction for increasing the free play.



Note

Please remember that the rear brake lever free play adjustment to be done only after adjusting the front brake lever play incase of SBS type brake (Drum type).

Brake shoe wear indicator (Rear brake)

When brake is applied, the wear limit indication pointer (1) on the rear brake cam lever should be within the wear limit indicator (2) on the crankcase LH.

In case the wear limit indication pointer (1) is going below wear limit indicator (2), index the lever to next slot with the help of Dealers to extend shoe life.



Caution

Replace the brake shoes as a set, if the wear limit indicator shows beyond the wear limit even after indexing the lever.

TYRES

Tyre pressure

Check the tyre pressure atleast once in a week if not more frequently. Insufficient air pressure in the tyres not only hasten tyre wear, but also seriously affects the stability of the vehicle.

Under inflated tyres make smooth cornering difficult and over inflated tyres decreases the tyre contact with the ground which can lead to skidding and loss of control.

Be sure that the tyre pressure is within the specified limit at all times.

Tyre pressure in cold condition:

	Solo	Dual
Front	1.68 kg/cm ² (24 PSI)	1.68 kg/cm ² (24 PSI)
Rear	2.25 kg/cm ² (32 PSI)	2.53 kg/cm ² (36 PSI)

Tyre tread condition

Operating the vehicle with excessively worn tyres will decrease riding stability and can lead to loss of control. It is recommended to replace the tyre when the tyre wears off to the tyre wear indicator level (indicated by TWI (A) on the tyre).

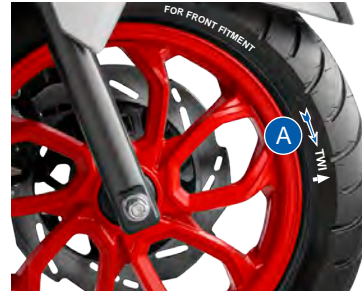

Warning

The tyre inflation pressure in cold condition and the tyre tread condition are extremely important for the performance and safety of the rider. Check the tyres frequently for inflation pressure as well as the wear pattern on it. Use of a tyre other than the standard may cause instability.

Tyre rotation direction

While reassembling the tyre on the wheel rim, please ensure the following:

1. The front tyre (indicated by 'FOR FRONT FITMENT' on the tyre) should not be assembled to rear wheel rim.
2. The arrow mark on the tyre should match the actual direction of rotation of wheel (both front and rear wheels).

Tyre puncture

Your scooter is fitted with a tubeless tyre on both front and rear wheel. In case of any puncture / tyre damage, it is advised to visit the nearest tyre manufacturer Dealer or the tyre repair shops who knows the repairing method of tubeless tyre.

It is not necessary to remove the tyre from wheel rim always to attend a puncture, Even though it there is need of tyre removal, it is strongly recommended to use a tyre removal / fitment machine. If at all, tyre levers needs to be used, the levers should be free from sharp edges. Care should be taken not to damage the tyres and rims.



Caution

The side walls of the tubeless tyre which in contact with the wheel rim are only seals the air inside the wheel assembly. Hence care should be taken not to damage the side walls of the tyres during removal / reassembly.



Tyre Maintenance Tips

Inflation Pressure Check - Condition



Note

If vehicle is in hold condition for long time

- *Need movement of vehicle to avoid particular spot of tyre not to touch the ground for more than week time.*
- *Inflation pressure should check on cold condition maximum travel time should not exceed more than 1 km.*
- *Weekly basis inflation pressure check helps to improve 10% of tread life & fuel efficiency.*

FRONT WHEEL REMOVAL AND REASSEMBLY

1. Remove the axle nut (1) along with a washer.
2. Pull out the axle (2) along with a washer and take out a spacer from the left side of the wheel.
3. Place a support below the foot board to prevent vehicle from falling and lift the vehicle up.
4. Dislocate the wheel disc from caliper assembly and take out the wheel along with hub drive.
5. Reverse the procedure for reassembling. Ensure the proper seating of wheel disc in the caliper assembly and lug on fork leg R to the slot in the hub drive while reassembling.



REAR WHEEL REMOVAL AND REASSEMBLY

1. Place the vehicle on the centre stand.
2. Hold the rear brake firmly and remove the wheel mounting nut (1) along with a washer.
3. Slightly tilt the vehicle and take out the wheel from the rear axle.
4. Reassemble the wheel in the reverse order of removal.



Caution

Always make sure, whenever the wheel is removed, the axle nuts are tightened properly to the specified torque.

STORAGE PROCEDURES

For storage of your scooter for longer period of over a month and above, we recommend to carry out the following steps:

1. Clean the vehicle thoroughly. Park the vehicle on centre stand.
2. Warm up the engine and drain engine oil and transmission oil. Store the oil, if new, in a dust free container.
3. Empty the fuel tank.
4. Remove the spark plug and feed in several drops of engine oil through spark plug hole. Crank the engine few times and reinstall the spark plug.
5. Remove the battery, store it away from direct sunlight and freezing temperatures.
6. Place a suitable support at the bottom of the foot board so that both the tyres are off the ground. This will ensure better tyre life.
7. Cover up the vehicle completely with a clean tarpaulin or any other suitable cover. Store the vehicle inside a garage or similar area to avoid damage due to dust and rain. Make sure that the storage area is well ventilated and free from any source of flame or spark.



Caution

Do not park the vehicle on a slope or soft ground or else it may fall down.

The exhaust system becomes hot after a run. Park the vehicle in a place where pedestrians or children are not likely to touch the vehicle.

During storage, the battery must be recharged at recommended charger if stored more than a month.

TAKING THE VEHICLE OUT OF STORAGE FOR REGULAR USE

1. Take the vehicle out of garage and clean it thoroughly.
2. Remount the battery after bench charging if required.
3. Fill the engine oil (TVS TRU4 SKUUTA oil - SAE 10W30 API-SL, JASO MB) and check the oil level using gauge oil level.
4. Fill the transmission oil (TVS TRU4 SKUUTA oil - SAE 10W30 API-SL, JASO MB) and check the oil level at the oil level screw.
5. Lubricate the parts as instructed in the periodic maintenance schedule.
6. Fill up fresh petrol in the fuel tank.
7. Check and inflate the tyres to the specified tyre pressure.
8. Check and correct the points mentioned in page No. 64.
9. Turn the ignition switch to 'ON' position. Turn ON the engine kill switch. Retract the side stand if the vehicle is parked on side stand. Start the vehicle and ride out.



Caution

Avoid using alkaline solution like detergent soaps for washing. This may damage head lamp and other lamp assemblies.

RECOMMENDED TIPS WHEN TAKING A LONG TRIP OF MORE THAN 500 KM:

- A) Please keep the following items for use in case of emergency:
1. Tool kit complete.
 2. Recommended spark plug one number.
 3. Turn signal lamp bulb each one.
 4. Throttle and rear brake cable each one.
 5. First aid kit.
- B) Precautions to be taken for the journey:
1. Ensure engine oil and transmission oil are up to the level.
 2. Adequate fuel in the fuel tank.
- C) Check your scooter for the following:
1. Tightness of all bolts and nuts with correct torque value.
 2. Fitness of tyres / tyre pressure / tread depth.
 3. All bulbs, indicators and horn functioning.
 4. Smooth functioning of all cables and their free play.
 5. Smoothness of steering operation.
 6. Front / rear brake function and rear brake lamp working.

7. Front fork for any abnormality.
8. Spark plug gap and condition of spark plug.
9. Air filter element cleanliness.
10. Lubrication of all items mentioned in the periodic maintenance schedule.
11. Any other job as necessary.
12. Have your vehicle checked at any TVS Motor Company Authorised Main Dealer or Authorised Dealer.



Caution

Long journey are to be taken only after the running-in period of 1000 km.

TVS Motor Company Limited ('the Company') give this warranty with respect to the TVS NTORQ 125 Race XP manufactured by the Company.

While the Company has taken every care to maintain quality in the manufacture of the TVS NTORQ 125 Race XP, the above said warranty is subject to other terms of warranty:

During 5 years from the date of purchase or during the first 50,000 km of run for the vehicle, whichever is earlier, the parts of the vehicle covered under warranty which prove to the satisfaction of the Company to have a manufacturing defect will be repaired or replaced free of cost. In the event of a change in the vehicle ownership, the remaining warranty period is effective for the new owner.

The Company's obligation under this warranty is limited to repairing or replacing, free of cost, those parts of the vehicle which upon examination by the Company may prove to the Company's satisfaction to have a manufacturing defect, and in such cases the Company's decision either to repair or replace the affected parts will be final. In the event of replacement of parts, the Company also reserves the right to use parts of the same brand as the affected parts or any other brand which is used by the Company in the course of manufacture. All parts replaced under this warranty will become the property of the Company and must be returned to the company.

Limitations of Warranty:

This warranty shall not apply to following condition:

1. Any natural wear and tear, including without limitation, aging.
2. Warranty claims on proprietary items such as tyres, tubes and batteries etc., should be preferred by the user directly on the respective manufacturer, as per their warranty terms and the Company shall not be liable in any manner in respect to the same.
 - Battery warranty for "MF type (Maintenance Free)" is applicable for a period of 21 months from the date of charging or 18 months from the date of sale or 20,000 kms, whichever is earlier.
 - Battery warranty for "Lead Acid type" is applicable for a period of 15 months from date of charging or 12 months from date of sale or 10000 kms whichever is earlier.



3. Parts repaired or replaced under this warranty are warranted only throughout the remainder of the original warranty period.
4. The Company is not liable for any delay in servicing due to reasons beyond the control of the Company or any of its Authorised Main Dealers / Authorised Dealers.
5. In any event, the Company is not liable for indirect, remote, incidental or consequential damages.
6. The Company may make any modification or improvement to vehicles in future production at any time without prior notice and without any obligation to install the same on vehicles previously dispatched for sale.
7. Any claim under this warranty will lie only when the customer:
 - takes his vehicle to an Authorised Main Dealer / Authorised Dealer of the Company and reports the problem he / she felt in the vehicle to enable the Authorised Main Dealer / Authorised Dealer to inspect the same and assess the cause for the reported problems.
 - produces to such Authorised Main Dealer / Authorised Dealer the Service Handbook for the concerned vehicle for verification of relevant details.
8. This is the only warranty given by the Company for the TVS NTORQ 125 Race XP. No employee, Dealer or other person is authorised to extend or enlarge this warranty.

Following Toll Free numbers can be contacted for battery related queries if any.

In the case of EXIDE battery, call :- 1800 103 5454

In the case of AMARON battery, call :- 1800 571 5858

In the case of TATA GREEN battery, call :- 1800 419 8888

Following Toll Free numbers can be contacted for Tyre related queries if any.

In the case of TVS Srichakra, call :- 04522443300

In the case of JK tyre, call :- 18002581100

In the case of Maxxis tyre, call :- 1800 532 2888

In the case of Ceat tyre, call :- 1800 22 1213

List of parts not covered under warranty

ITEM	WHAT TO CHECK FOR
Normal Maintenance operations	Engine tune-up, decarbonizing, fuel system cleaning, oil changes, head light focusing, fastener retightening, ignition timing, clutch and brakes as well as other normal adjustments.
Wear & tear items	Chain, sprockets, clutch and brake linings, fasteners, shims, washers, oil seals, gaskets, O' rings and spokes etc.
Electrical	Bulbs , fuse, DRL, AHO
Service Maintenance Parts	Oil filters, spark plug, air filter, SAI filter, oils and brake fluid
Rubber, rexine & plastic items	All hoses, pipes and plastic aesthetics
Proprietary Items	Battery, tyres and tubes (the warranty terms are subject to our agreement with proprietary OEM)
Other Factors	Parts of the vehicle getting affected due to atmospheric effect / environmental factors (rusting, paint peel off etc.). However, depending on the vehicle usage condition, warranty would be accepted up to 2 years from the date of purchase.
	Parts of the vehicle which have been tampered with, altered, repaired or replaced by persons not authorised by the Company and which in the sole judgement of the Company affect the performance of the vehicle.
	Parts which are used in conjunction with parts not made or recommended by the Company.

List of parts not covered under warranty

ITEM	WHAT TO CHECK FOR
Other Factors	Parts suffering damage or resultant damage by accident, misuse, negligent treatment, use of bad quality lubricants or impure fuel or by omission to follow the guidance and instructions contained in this user's manual.
	Vehicles on which engine number or chassis number is deleted, defaced or altered.
	Vehicles on which any warranty service including scheduled paid service is not availed when it falls due (at TVS Motor Company Authorised Main Dealer / Authorised Dealer).
	<p>Vehicles used for racing or any competition or used otherwise than for ordinary personal transportation.</p> <p>Vehicles attached with side cars etc.</p> <p>Vehicles which have been taken out of India.</p> <p>Vehicles affected by natural calamities like flood, earthquake, tsunami, storm etc,.</p>
	If the vehicle has been used for commercial purpose like taxi or used for rental or hiring or any other purpose other than regular personal transportation.

Warning

Modifications to this vehicle not approved by the TVS Motor Company may cause loss of performance and render it unsafe for use and disqualifies for warranty coverage also.

SERVICE INFORMATION

There are seventeen services for TVS NTORQ 125 Race XP during warranty period. Of these, first four services are free services for which labour charges are free. In addition to these four free services, we have a scheme of thirteen pay services. For keeping the maintenance track of your vehicle, free and pay service record sheets are attached in the Service Handbook given to you during the time of your vehicle purchase. Please have the relevant record sheet filled by the Dealer who is carrying out the maintenance service.

For availing any of the warranty services, please take your vehicle and your Service Handbook to any of our Authorised Main Dealers or any of our Authorised Dealer. After effecting the service the Authorised Main Dealer or the Authorised Dealer will affix their stamp on the last column of free or pay service record sheet of Service Handbook for your record and reference.

Periodic maintenance always helps good performance of an automobile and our services are planned to keep your TVS NTORQ 125 Race XP performing good. **Please note that carrying out the services for your vehicle at scheduled intervals at any of the TVS Motor Company Authorised Main Dealer / Authorised Dealer is necessary for availing of warranty.** And please also remember that, after the services are over, periodic servicing of your vehicle at appropriate intervals, depending upon its extent of use, will keep your vehicle at its best level of performance.

In case you need any clarification or assistance, please feel free to write to us mentioning the frame number, engine number and date of purchase of your vehicle also the name and place of the Authorised Main Dealer / Authorised Dealer from whom you bought the vehicle and getting it serviced.

Service Department

TVS MOTOR COMPANY LIMITED

P.O. Box No. 4, Harita, Hosur - 635 109,

TAMILNADU, INDIA.

Toll free no:- 1800-258-7111

Planned Service Schedule (kms or month whichever of the two occurs early)*

Sl.No.	Service	Type	Kms	Months
1	1st Service	Free	500 ~ 750	2
2	2nd Service		2500 ~ 3000	4
3	3rd Service		5000 ~ 6000	8
4	4th Service		8500 ~ 9000	12
5	5th Service	Pay	11500 ~ 12000	16
6	6th Service		14500 ~ 15000	20
7	7th Service		17500 ~ 18000	24
8	8th Service		20500 ~ 21000	28
9	9th Service		23500 ~ 24000	32
10	10th Service		26500 ~ 27000	36
11	11th Service		29500 ~ 30000	40

Sl.No.	Service	Type	Kms	Months
12	12th Service	Pay	32500 ~ 33000	44
13	13th Service		35500 ~ 36000	48
14	14th Service		38500 ~ 39000	51
15	15th Service		41500 ~ 42000	54
16	16th Service		44500 ~ 45000	57
17	17th Service		47500 ~ 48000	60

Note

Free service enables the customer to avail the service at free of labour charges. Charges for the pay service should be borne by the customer. Cost of engine oil, periodic maintenance parts, filter, brake fluids, all types of greases, petroleum jelly, distilled water, chain cleaner, lubricants, coolants, cleaning cloths for both free and paid services are chargeable to the customer.

* Please remember that, after the above schedule, periodic servicing of your vehicle at appropriate intervals, depending upon its extent of use, will keep your vehicle at its best level of performance.

Your Privacy is of paramount importance to us. We are committed to safeguarding your privacy and protecting your Personal Data that is with us. This Privacy Notice outlines the details of the Personal Data we collect and process, how we handle it and the purposes for which we use it. Please read the following carefully to understand our practices regarding your Personal Data.

Throughout this document, the terms “we,” “us,” “our” & “ours” refer to TVS Motor Company Limited. And the terms “you,” “your” & “yours” refer to YOU (the individual whose Personal Data we are referring to).

**What Personal Data Do We Collect, Store and Process?
Categories of Personal Data that we collect, store and process are as follows:**

- I. Demographic, Identity & Contact Data (for e.g., name, last name, date of birth, gender, email address, address proof, contact number, language, occupation, physical address with pin code, preferences and interests.)
- II. Personal Identification Number (for e.g., PAN Card No, Voter ID, GST no, Passport and Aadhaar Number)
- III. Financial Account Details (for e.g., Bank Details, PF Details, Past Salary,)
- IV. Educational & Professional Data (for e.g., Education, Profession, Employment Type, work experience, Income, Tax category, Performance History.)
- V. Online Identifiers and other Technical Data (for e.g., IP address, browser type, device identifiers)
- VI. Personal Data collected via permissions on our mobile applications (for e.g., camera, contacts, location data, storage, photos, fingerprint/biometric and SMS)
- VII. Vehicle Data (for e.g., registration number, Registration type, registration data, VIN Number and Model type.
- VIII. Ride Data (for e.g., Mileage, travel location, travel date, time, top speed, average speed, driver behaviour data such as speed and braking habits.)
- IX. Subscriptions and Add on Data (for e.g., Subscription Plan, Plan Start Date, Plan End Date, Premium Paid.)
- X. Charging Details (for e.g., Charger Name, Charger Model, Start time, End time, Distance Available, Payable Amount)
- XI. Telematics Data (for e.g., data about speed, bike fall and crash)
- XII. Communications details (for e.g., communication done through emails)Generated Data (for e.g., logs, transaction records)
- XIII. Information relevant to surveys that we undertake.
- XIV. Testimonials and feedback that may contain some Personal Data.

Where Do We Collect Your Personal Data From?

We collect your Personal Data in the following ways:

- I. When you visit our website or social media pages and fill in the registration form and use the Contact Us facility.
- II. When you use our mobile applications.
- III. When you interact with us via our websites or use services on our websites including customer support.
- IV. When you use the connected features on our vehicle
- V. When you interact with our dealers.
- VI. When you apply for a job at TVSM
- VII. When we onboard you as an employee and during your subsequent interactions with us as an employee

How Do We Use Your Personal Data?

We use your Personal Data for the following purposes:

- A. If you express an interest in our services, we collect and share your Personal Data with our dealer, who in turn would contact you to schedule a store visit.
- B. If you are an existing customer, we collect your Personal Data for the following purposes:
 - I. to authenticate your account or information on our applications that you use.
 - II. to provide you with our products and services
 - III. to cross sell vehicles on our App/website

- IV. to communicate with you regarding existing products and services availed by you, including notifications of any alerts or updates.
- V. to evaluate, develop and improve our services.
- VI. to manage sales and refunds
- VII. to manage your subscriptions and add on
- VIII. for market and product analysis and market research.
- IX. to send you information about our other products or services which may be of interest to you.
- X. to obtain feedback and handle enquiries and complaints.
- XI. to comply with legal or regulatory requirements.
- XII. to reach out to you for service reminders.
- C. If you are a dealer, we collect your Personal Data for onboarding and invoicing purposes.
- D. If you are a website visitor, we process your Personal Data to optimize your website experience and customize content.



On What Legal Grounds Do We Process Your Personal Data?

We process your Personal Data by relying on one or more of the following legal grounds:

- I. You have consented to us processing your Personal Data for specified reasons.
- II. You have voluntarily provided your Personal Data to us for specified reasons.
- III. To evaluate, develop and improve our products and services.
- IV. The processing is necessary for compliance with a legal obligation we may have towards other stakeholders like law enforcement agencies, government agencies, regulators, etc.

Where the processing is based on your consent, you have the right to withdraw your consent at any point in time. Upon receipt of your request to withdraw your consent, the consequences of withdrawal will be communicated to you. In many cases, upon such a withdrawal, we may not be able to continue offering our products and services to you. You may withdraw consent by contacting us using the details specified in the 'Contact Us' section.

Who Do We Share Your Personal Data With?

We may disclose your Personal Data to:

- I. Our Parent Company for business and operational purposes;
- II. Our affiliates or group companies;
- III. Our Dealer; and/or
- IV. Third Party Service Providers who work for us or provide services or products to us.

We may also share your Personal Data under the following circumstances:

- I. To respond to court orders, or legal process, or to establish our legal rights or defend against legal claims.
- II. if we are acquired by or merged with another company.

International Data Transfer

The data collected from you is stored in India We may transfer your Personal Data to other countries outside your country of residence for any of the purposes defined in this Privacy Notice to the entities mentioned above. Any Personal Data that we transfer will be protected in accordance with this Privacy Notice.

How Do We Secure Your Personal Data?

We are committed to protecting your Personal Data in our custody. We take reasonable steps to ensure that appropriate physical, technical and managerial safeguards are in place to protect your Personal Data from unauthorized access, alteration, transmission, and deletion. We train our employees about the importance of maintaining the privacy and security of your Personal Data. We ensure that the third parties with whom we share your Personal Data under appropriate contracts; take appropriate security measures to protect your Personal Data in line with our policies.

How Long Do We Keep Your Personal Data?

We retain your Personal Data for as long as it is required to fulfil the purposes outlined in this Privacy Notice and for legal or regulatory reasons.

How Do We Use Cookies and other Tracking Mechanisms?

We use cookies and other tracking mechanisms on our website to collect data about you. We use the data collected from cookies and trackers to analyze trends and statistics. This will help us optimize and customize your website experience and to provide better website functionalities.

We collect Personal Data about you via Mobile Applications using permissions such as camera contacts/telephone, location, photo, SMS, etc. Your iOS and Android devices will notify you of the permissions that our app seeks and will provide you an option to consent to or refuse the permission. We use the data obtained through permissions to provide the functionalities through the Mobile Applications.

What Are Your Privacy Rights?

You have certain rights regarding your Personal Data that is with us, and we commit to provide you with them.

Right to Confirmation and Access: You have the right to get confirmation and access to your Personal Data that is with us along with other supporting information.

Right to Correction: You have the right to ask us to correct your Personal Data that is with us that you think is inaccurate. You also have the right to ask us to complete your Personal Data that you think is incomplete.

Right to Erasure: You have the right to ask us to erase your Personal Data that is with us under certain circumstances.

Right to Nominate: You have the right to nominate a person who can manage your personal data on behalf of you.

Right to Lodge a Complaint with the Authority: You have the right to lodge a complaint with the Regulator. If you wish to make a request to exercise any of your rights, you can contact us using the details in the **'Contact Us'** section of this Privacy Notice.

Links to Other Websites

Our website may contain links to websites of other organisations. This Privacy Notice does not cover how that organisation processes Personal Data. We encourage you to read the Privacy Notices of the other websites you visit.

How Do We Keep This Notice Up to Date?

We regularly review and update our Privacy Notice to ensure it is up-to-date and accurate. Any changes we may make to this Privacy Notice in the future will be posted on this page. When we post changes to this Privacy Notice, we will revise the "last updated" date.

Limitation of Liability

To the extent permissible under the law, we shall not be liable for any indirect, incidental, special, consequential or exemplary damages, including but not limited to, damages for loss of profits, goodwill, data, information, or other intangible losses (even if we have been advised of the possibility of such damages), arising out of this Privacy Policy.

Governing Law, Jurisdiction and Dispute Resolution

This Privacy Policy shall be construed and governed by the laws of India without regard to principles of conflict of laws. All disputes, differences, claims, controversies and the like, which may arise between the parties to this Privacy Policy, including construction, meaning or operation or effect of the same shall be referred to sole arbitration of an arbitrator to be nominated by the MCCI Arbitration, Mediation and Conciliation Centre (MAMC), The Madras Chamber of Commerce and Industry, 'Karumuttu Centre', First Floor, No. 634, Anna Salai, Nandanam, Chennai – 600 035, at the request of the authorised signatory of either TVS Motor or yourself, as the case may be, and such arbitration shall be conducted in accordance with the provisions of the Arbitration and Conciliation (Amendment) Act, 2021, or its statutory amendments, and in accordance with the MAMC's Rules of Arbitration and Conciliation or its amendments, in English language, and the seat of arbitration shall be at Chennai; the venue of arbitration shall be as per the choice of the MAMC-appointed arbitrator. The Award passed by the Arbitrator shall be final and binding on both the Parties.

How Do You Contact Us?

For any further queries and complaints related to privacy or exercising your rights, you could reach our Data Protection Officer at the following address:

**Chief Information Security Officer At
dpo@tvsmotor.com**

Business Address:

**Prathik Tech Park,
93/4, Veerasandra Village,
Attibele Hobli, Electronic City,
Bengaluru, Karnataka 560100**

MANUFACTURER : TVS MOTOR COMPANY LIMITED
P.B. No1, Bythahalli, Kadakola post, Mysore - 571 311, India.

TVS MOTOR COMPANY LIMITED
Village Bhatian, Bharatgarh Road, Teh Nalagarh, Dist. Solan.
Himachal pradesh - 174 101, India.

ENGINE

Type	: Single cylinder, 4 stroke, fuel injection, air cooled, spark ignition engine	Engine idling rpm [†]	: 1500 ± 200 rpm (Street mode) 1750 ± 200 rpm (Race mode)
Cylinder bore	: 53.5 mm	Starting system	: Electric starter / Kickstarter*
Stroke	: 55.5 mm	Emission norms	: BSVI
Piston displacement	: 124.8 cc		
Compression ratio	: 10.3 ± 0.3 : 1		
Air filter	: Dry paper filter with dry foam		
Oil filter	: Wire mesh		
Lubrication system	: Forced wet sump		
Maximum power in kW	: 6.6 kW @ 7000 rpm (Street mode) 7.5 kW @ 7000 rpm (Race mode)		
Maximum torque in Nm	: 10.0 Nm @ 5500 rpm (Street mode) 10.9 Nm @ 5500 rpm (Race mode) (without Assist) 11.5 Nm @ 5500 rpm (Race mode) (with Assist)		
Maximum speed	: 89 km/h (Street mode) 98 km/h (Race mode)		

TRANSMISSION

Clutch	: Dry - Centrifugal clutch
Primary transmission	: CVT (Continuous Variable Transmission)
Primary reduction	: 2.65 to 0.8
Secondary reduction	: 9.085

CHASSIS

Overall length	: 1861 mm
Overall width	: 710 mm
Overall height	: 1164 mm

[†] Under warm condition

* Mandatory accessory will be charged extra

CHASSIS

Ground clearance	: 155 mm (unladen)
Wheel base	: 1285 mm
Kerb weight (with toolkit and 90% of fuel)	: 111 kg
Pay load	: 150 kg
Maximum laden weight	: 261 kg
Frame	: Under bone tubular frame
Front suspension	: Telescopic hydraulic
Rear suspension	: Toggle link, gas filled hydraulic damper
Steering angle	: 90°
Caster angle	: 25°

TYRE

Tyre size

Front	: 100/80 - 12 56L Tubeless
Rear	: 110/80 - 12 61L Tubeless

Tyre pressure

Front	: 1.68 kg/cm ² (24 PSI)
Rear - solo	: 2.25 kg/cm ² (32 PSI)
Rear - dual	: 2.53 kg/cm ² (36 PSI)

BRAKES

Front	: 220 mm dia Disc (hand operated)
Rear	: 130 mm dia Drum (hand operated)

ELECTRICAL

Ignition system	: ECU controlled ignition
Spark plug	: BOSCH - UR5KCW / CHAMPION - RG8MC4
Spark plug gap	: 0.9 to 1.0 mm
Battery type	: 12V, 4Ah / 3Ah MF battery
Generator	: Fly wheel magneto 12V, 130W
Head lamp	: 12V, LED (AHO)
DRL / Position lamp	: 12V, LED
Tail / brake lamp	: 12V, 1/2W LED
Turn signal lamp	: 12V, 10W x 4
Number plate lamp	: 12V, 5W
Instrument cluster	: Fully digital connected instrument cluster
Horn	: 12V, 2.5A DC
Fuse	: 15A x 1 (Blade type) : 10A x 2 (Blade type)



Caution

Using the bulb other than the specified rating can result in overloading of the electrical system or premature failure of the bulb.

CAPACITIES

Fuel tank capacity [#]	: 5.8 l
Fuel	: BS VI petrol with minimum RON 98 (containing upto 20% of ethanol by volume)
Engine oil grade	: TVS TRU4 SKUUTA oil (SAE 10W30 API-SL, JASO MB)
Engine oil capacity	: 880 ml (during regular service) 930ml (incase of disassembly)
Transmission oil capacity	: 120 ml (during regular service) 130ml (incase of disassembly)
Front fork oil grade	: IOC / HPCL / Castrol - Gabriel Premium front fork oil
Front fork oil capacity	: 91 ± 1 cc per leg
Brake fluid	: TVS Girling DOT 3 / DOT 4

Note

Specifications are subject to change without notice.

[#] *The fuel tank is not a measuring instrument and the capacity of fuel tank may slightly vary from the indicated capacity.*

Dear Customer,

It is mandatory under the Motor Vehicles Act to insure all motor vehicles. No motor vehicle can be used in a public place without a valid policy of insurance issued by an authorised insurer. Driving a motor vehicle without any such insurance is an offense under Motor Vehicles Act.

To assist our Customers on their insurance requirements such as the prompt issue and renewal of policies as well as expeditious settlement of claims if any, our preferred insurers are:





ALWAYS USE TVS-M GENUINE PARTS



TVS MOTOR COMPANY LIMITED

P. B. No. 4, Harita, Hosur - 635 109, Tamil Nadu, India.

Telephone: +91 (4344) 276780 | Fax: +91 (4344) 277311/276878

Website: www.tvsmotor.com | Toll-free No.: 18004252077