

TVS *Racing*

TVS 



Apache
RTX

GRIT TO GLORY

User Manual



Revision:- Rev 1, 6th Jan 2026 onwards

FOREWORD	1
CONTACT(S) FOR SUPPORT	2
INTRODUCTION	6
RUNNING-IN INFORMATION	8
SAFE RIDING TIPS	9
ACCESSORY INSTALLATION TIPS	13
KNOW YOUR MOTORCYCLE	14
CONTROLS & ITS OPERATIONS	27
RIDING YOUR MOTORCYCLE	125
GENERAL ADJUSTMENTS	133
MAINTENANCE	143
GENERAL INFORMATION	181
WARRANTY AND SERVICES	183
PICKUP AND DROP	192
TECHNICAL SPECIFICATIONS	193
INSURANCE	204

Welcome to the “Tribe!”

Congratulations on becoming the proud owner of the new TVS Apache RTX — a machine crafted for those who believe that adventure begins where the road ends.

Born from our relentless pursuit of performance and precision, this motorcycle embodies the spirit of “Grit to Glory” — the courage to push beyond limits and the passion to discover what lies ahead.

Every component has been engineered to give you confidence, control, and freedom on every terrain.

At TVS we take pride in building machines that connect man, machine, and nature in perfect harmony.

Your Apache RTX isn’t just a motorcycle; it’s a companion built to take you places you’ve only dreamed of — and to create stories that last a lifetime.

TVS MOTOR COMPANY LIMITED

Incase you need any Clarification please contact above Dealer

Or

TVS Motor Company's Area Offices (flip over for addresses)

Or

Toll Free Number : 1800-258-7111

Email : customercare@tvsmotor.com

Disclaimer : TVS Motor Company or any of its officials / Authorized Main dealer / Authorized Dealer do not ask customers for bank / card / wallet details / authentication. In case you face any such claim, please report to the relevant local authorities immediately.



Contact at Our Area Offices

TAMILNADU - 1

1. TVS Motor Company Limited

V Floor, Gee Gee Universal,
No. 2, MC Nichols Road,
Chetpet, Chennai - 600 031.
Phone : 044 - 28361651/28361654
Email : AO.Chennai@tvsmotor.com

TAMILNADU - 2

2. TVS Motor Company Limited

No. 10, 2nd floor,
Shree Shanmugapriya Towers,
Kannuswamy Street,
Behind Hotel Annapoorna,
R S Puram, Coimbatore - 641 002.
Phone : 0422 - 4350060/2541035
Email : AO.Coimbatore@tvsmotor.com

TAMILNADU - 3

3. TVS Motor Company Limited

Sastha Square, 2nd Floor,
No. 46/4,5, 46/6A6,
Bypass Road, Kalavasal,
Next to Bharat Petroleum, Ponmeni,
Chandragandhi Nagar,
Madurai - 625 016.
Email : AO.Madurai@tvsmotor.com

KERALA

4. TVS Motor Company Limited

Ambady Towers, Second Floor,
Door No. 27/631, A6,
Edappally-Pookkattupady Road,
Edappally PO., Cochin - 682 024.
Phone : 0484 - 2544578/2556938
Email : AO.Cochin@tvsmotor.com

KARNATAKA -1

5. TVS Motor Company Limited

TVS Focus Towers, Plot No. 25 and 23,
Konappana Agrahara Village,
Begur Hobli, Electronics City phase 1,
26A, 1st Main Rd,
Bengaluru - 560 100.
Email : AO.Bangalore@tvsmotor.com

KARNATAKA -2

6. TVS Motor Company Limited

5th Floor, Marvel Ecron building.
CTS No-4784/A1/B2
Gokul Road, Hubballi - 580 030.

TELANGANA

7. TVS Motor Company Limited

Rukamani Towers, First Floor,
No. 3-11-30, Plot No. 11,
Paigha Colony, Behind Anand Theater,
Secunderabad - 500 003.
Phone : 040 - 27840590/27844419
Email : AO.Hyderabad@tvsmotor.com

ANDHRA PRADESH

8. TVS Motor Company Limited

1st Floor, Passport Office Building,
Sri Venkateswara Theatre,
D.No. 38-8-45, MG road, Punnammathota,
Vijayawada - 520 010.
Email : AO.Vijayawada@tvsmotor.com

MAHARASHTRA - 1 & 2

9. TVS Motor Company Limited

Poloroche Business Avenue, #302,
3rd Floor, CTS No. 218/3, Airport road,
Opposite Symbiosis Law School,
Lohegaon,
Pune - 411 047.
Email : AO.Pune@tvsmotor.com

MAHARASHTRA - 3**10. TVS Motor Company Limited**

No. 502B, 6th Floor, B Wing,
Shriram Shyam Towers,
Near LIC Square, Sardar,
Nagpur - 440 001.
Phone : 0712 - 2569932
Email : Service.Nagpur@tvsmotor.com

CHATTISGARH**11. TVS Motor Company Limited**

Office No. B518- B527, 5th Floor,
Currency Tower, VIP Road Corner,
Raipur - 492 001.
Phone : 0771 - 4260006
Email : AO.Raipur@tvsmotor.com

GUJARAT**12. TVS Motor Company Limited**

101-08, 11th Floor, Solitaire Connect,
Near Gallops Motors,
S G Highway, Makarba,
Ahmedabad - 380 051.
Phone : 0755 - 65443748
Email : AO.Ahmedabad@tvsmotor.com

MADHYA PRADESH - 1**13. TVS Motor Company Limited**

No. 211-212, 2nd Floor,
Chinar Incube Business Centre,
Chinar Fortune City,
Near Brindhavan Dhaba,
Hosangabad Road,
Bhopal - 462 026.
Phone : 0755 - 2499406/2499306
Email : AO.Bhopal@tvsmotor.com

MADHYA PRADESH - 2**14. TVS Motor Company Limited**

501, N R K Tech Park,
5th floor, Plot No. 9-C-C-A,
Scheme No. 94, Ring Road,
Indore - 452 010.
Phone : 9685558301
Email : AO.Indore@tvsmotor.com

RAJASTHAN - 1 & 2**15. TVS Motor Company Limited**

Plot No. 17-18,
2nd Floor of National Motors Building,
Jhotwara Industrial Area,
Jaipur - 302 012.
Phone : 0141 - 5150901/5150902
Email : AO.Jaipur@tvsmotor.com
AO.Udaipur@tvsmotor.com

**DELHI, HARYANA, UTTAR PRADESH WEST
& UTTAR PRADESH HILLS****16. TVS Motor Company Limited**

Block D & E, Third Floor, "Golden-I",
Plot No. 11, Sector-Techzone - 4,
Gr. Noida West - 201 318.
Phone : 011 - 29834640/29834773
Email : AO.Delhi@tvsmotor.com

PUNJAB & CHANDIGARH**17. TVS Motor Company Limited**

4th Floor, Royal Business Park,
Chandigarh Ambala Highway,
Zirkapur - 140 603.
Phone : 01762 - 464777/465777
Email : AO.Chandigarh@tvsmotor.com

UTTAR PRADESH CENTRAL & EAST**18. TVS Motor Company Limited**

1st Floor, Cyber Tower, TC-34/V-2,
Vibhuti Khand, Gomti Nagar,
Lucknow - 226 010.
Phone : 0522 - 4918300/4918301
Email : AO.Lucknow@tvsmotor.com

WEST BENGAL

19. TVS Motor Company Limited

Mediasiti, 6th Floor, Plot No. XI-4,
Salt Lake City, Electronic Complex,
Sector-V, PE & GP block, PO-Sech,
Bhawan, P S - Electronics Complex,
Kolkata - 700 091.
Email : AO.Kolkatta@tvsmotor.com

BIHAR

20. TVS Motor Company Limited

Sai Corporate Park, Block-A, 4th Floor,
Bailey Road, Rukanpura,
Patna - 800 014.
Email : AO.BNJ@tvsmotor.com

ORISSA

21. TVS Motor Company Limited

No. 303, 3rd Floor,
Creative Plaza, Rasulgarh,
Bhubaneshwar - 751 010.
Phone : 0674 - 2580019
Email : AO.Bhubaneshwar@tvsmotor.com

JHARKHAND

22. TVS Motor Company Limited

Second Floor, Lucas Service Building,
Argora Bypass Road,
Ranchi - 834 002.
Phone : 0651 - 2244715
Email : AO.Ranchi@tvsmotor.com

NORTH EAST STATES

23. TVS Motor Company Limited

147, Udayan, Ganesh Guri,
Near Hotel D Courtyard,
R G B. Road, Guwahati - 781 005.
Phone : 0361 - 2202030/2202031
Email : AO.Guwahati@tvsmotor.com

TVS Motor Company Limited advises you to read this manual carefully in order to familiarise yourself with your motorcycle. In case of any clarification, please contact any of our Authorised Main Dealer.

This manual contains important information about controls and operation, technical features, maintenance and care to be taken to keep your vehicle reliable and safe. We recommend that you strictly follow the instructions in this manual, especially those regarding the running-in period and periodic maintenance.

TVS Motor Company Limited declines any liability whatsoever for any mistakes incurred during the development of this manual. All the information in this manual is valid at the time of publication.

TVS Motor Company Limited reserves the right to make any modifications required due to the ongoing development of their products. In such events it is possible that the relevant part of this User's Manual does not apply to your vehicle.

Prior permission of TVS Motor Company Limited is required for quoting, copying or reproducing any part of this User's Manual.

This User's manual uses a set of symbols with special meanings. They are:

 **Warning**

*Disregarding this message might result in **injury to the rider or deadly accidents.***

 **Caution**

*This message indicates special procedures or precautions to be followed to **avoid damage to the vehicle.***

 **Note**

*This message provides further clarification for **clear understanding of any particular information.***

The terms 'LH' and 'RH' are referred to the motorcycle viewed from the riding position.

Accessories shown in the picture may not be the part of standard equipment.

For your safety, as well as to preserve warranty, reliability and road worthy of your motorcycle, use original TVS Motor Company Limited spare parts only.

In order to ensure the reliability of your product, you are strongly advised to refer our Authorised Main Dealers for any service requiring particular technical expertise.

Skilled personals of our Dealer have the tools required to perform any servicing job to the highest professional standards to ensure smooth running and long life of your motorcycle.

Running-in Recommendations

Running-in is essential to preserve engine life and performance over time. Twisty roads and gradients are ideal to run in the engine, brakes and suspension effectively. The first 1000 km is a running-in period for your motorcycle.

Maximum engine speed during running-in 0 to 1000 km - below 7000 rpm.

During the first 1000 km, avoid the full throttle starts and rapid acceleration, which could expose the engine parts to excessive stress. It is advisable to run the engine at varying load and rpm, though still within recommended rpm limit. Avoid riding at constant engine rpm for prolonged periods.

During initial running, use brakes gently. Do not brake hard or keep brake applied for too long to enable a correct break-in of brake pad friction material against the brake discs. To allow all the mechanical parts of motorcycle to adapt each another, and to avoid reduction of engine components life, it is advisable to avoid sudden acceleration and running the engine at high rpm for too long, especially uphill.

Check the drive chain frequently and if required adjust it. Also ensure that the chain is lubricated as required to increase its service life.



Caution

On completion of running-in period, scheduled maintenance service should be observed carefully without fail. Failure to comply with this will result in damage to the engine parts and other key parts of the vehicle or shorter engine life. Keeping to the running-in recommendations will ensure longer engine life and reduce the need for overhauls and re-tuning.

Safe Riding Recommendations

The following points are applicable for every day usage of your motorcycle and should be observed carefully for safe riding of your motorcycle.

Riding skills and your mechanical knowledge forms the foundation of safe riding practices. We suggest you to practice riding your TVS Apache RTX in a low-traffic condition until you are thoroughly familiar with your motorcycle and its controls.

Most of the accidents are the result of inexperience of rider. You must have a valid license that enables you to ride a motorcycle of this kind. Always make sure you are carrying your driving license with you. Avoid lending your motorcycle to the persons who are inexperienced and not holding a valid driving license.

A motorcycle is not designed to provide impact protection, so defensive riding in addition to wearing of protective apparel is very important.

Please do not let the protective apparels give you a false sense of security.

Both the rider and the pillion should always wear an ISI approved, comfortable and good quality safety helmet before riding the vehicle. Because, one of the most serious injury that can happen is an head injury. You should also have a good quality goggles to protect your eyes and help your vision.

Avoid wearing loose clothes or accessories that could become tangled in the controls or limit your field of vision.

Riding at proper speed and avoiding sudden acceleration are not only important for safety and low fuel consumption. It is also important for longer life of vehicle and smoother operation.

Avoid use of mobile phones while riding as it could lead to fatal accident.

To prevent or minimise accident, never consume alcohol or drugs before or during the operation of your vehicle. Even minimal consumption of these will affect the rider's ability to control the vehicle.

Ride within the law and observe national and local rules. Always respect speed limits. However, adjust your speed according to the visibility, road and traffic conditions.

Be sure about your visibility and do not ride with the blind spot of vehicles or obstruction ahead you.

Take additional care at road junctions, exits of private land, car parks and on the service roads to highways.

Before changing the lanes or take a turn, look over your shoulder and make sure that your way is clear. Do not completely rely on the rear view mirrors; you may misjudge a vehicle's distance and speed, or you may not see it at all.

Always use turn signal lamps when you intend to change lanes or take a turn. Be sure to switch it off after changing the lane or negotiating the corner.

The rider should keep his/her foot on the footrests while riding the motorcycle.

Always hold the handlebars firmly with both hands in order to be ready for sudden changes of direction or in the road surface.

Under no circumstances should both the hands be removed from the handle bar, as it is very dangerous.

While riding in wet conditions, on loose gravels, the ability to maneuver the vehicle will be reduced. Ride smoothly on this conditions. Sudden acceleration, braking or turning may cause loss of control.

On the wet roads, rely more on the throttle to control vehicle speed and less on the front and rear brakes.

Use the throttle judiciously to avoid skidding the rear wheel from too rapid acceleration or deceleration.

On the rough roads, exercise caution, slow down and grip the fuel tank with your knees for better stability.

To get quick acceleration during overtakes, shift to a lower gear to obtain the necessary power.

Do not downshift the gear abruptly at high rpm to avoid damage to the engine due to overrevving.

Avoid unnecessary weaving for the safety of both the rider and other motorists.

While riding on uphill, shift to a lower gears so that there is plenty of power to spare rather than overloading the engine.

Do not downshift the gears in the midst of cornering. Slow down to a safe speed before negotiating a corner.

Hold the vehicle upright as you apply the brake. Progressive application of brake is safer. Never depress the clutch lever while braking at higher speeds.

Riding down hills, while cornering, close throttle and down shift the gear to take advantage of gear box and engine which acts as additional brake. This will avoid loss of control over the vehicle due to over speed.

Do not ride the vehicle with two hands off from the handlebar considering the safety of the rider and the vehicle.

As the vehicle speed increases, the stopping distance also increases. Progressive application of brake is safer.

Fuel (petrol) is extremely flammable and is explosive under certain conditions. Refuel in a well ventilated area with engine stopped and ignition key turned off.

Do not smoke or use cell phones or allow open flame or sparks when re-fueling or servicing the fuel system.

While re-fueling, there may be a chance of fuel drops getting spilled on your skin or cloths. Wash your skin with soap or change your cloths immediately if you come in contact with the fuel.

Always take out the key when you leave your motorcycle unattended.

Do not park the vehicle on a uneven surface or a slope or a soft ground or else the vehicle may fall.

The exhaust system becomes hot after a run even if the engine is turned 'OFF'. Care should be taken not to touch the exhaust system with any part of your body. Park the vehicle in a place where pedestrians or children are not likely to touch the vehicle. Do not park the motorcycle near inflammable material like wood, dry leaves etc.

 **Warning**

Do not ride the motorcycle with helmets attached to the hook; the helmets could cause an accident by distracting the rider or interfering with normal vehicle operation.

 **Caution**

Do not place any combustibile material like cloth, paper, vinyl bag etc. near the engine area.

Additional Safety Parameters

- Please ensure that no cloth or flammable material is kept near the engine or exhaust area, as these components become extremely hot during operation. Any such contact may lead to a potential thermal incident, causing damage to the vehicle and posing a safety risk.
- Please avoid using tie ropes/cords on the motorcycle while carrying luggage. These ropes may come in contact with the exhaust or other hot components, which can result in melting, burning, or a potential thermal incident.



Fig. 01

- Please avoid using non-OEM accessories or carrying out any tampering/modifications in the wiring harness, fuse box, or electrical circuits. Such alterations may compromise the vehicle's electrical integrity, potentially leading to a thermal incident, short circuit, or damage to critical electrical components.
- Please avoid covering the motorcycle immediately after use. When the vehicle is still hot, especially around the engine and exhaust areas, placing a cover over it can trap heat and may result in a potential thermal incident or damage to the cover and nearby components. Allow the vehicle to cool down completely before putting on the cover to ensure safety and prevent any heat-related issues.

Note

A caution sticker is pasted near the rear brake fluid reservoir, displaying all the necessary safety information. Please read it carefully and follow the instructions to prevent any potential hazards (ref. Fig. 01).

Use only TVS Motor Company Limited approved accessories.

Take extreme caution while selecting and installing the accessories for your motorcycle.

The addition of unsuitable accessories can lead to unsafe operating conditions. Your friendly dealer will assist you in selecting quality accessories and installing them correctly.

While selecting the accessories, make sure the accessories should not obstruct lighting, steering, suspension and ground clearance.



Caution

This motorcycle was not intended to be equipped with a sidecar or to be used to tow any trailer or other vehicle.

TVS Motor Company Limited does not produce any of those things and not sure about the effects of those accessories on handling or stability. But we can warn that the effects will be adverse and any damage caused to motorcycle and its components by the use of such accessories will not be covered under warranty.

Additional electrical equipments and controls should not exceed the specified electrical system load of the vehicle (capacity of battery and magneto).

Do not change / add any lighting loads. Use only accessories listed by TVS Motor Company Limited.



Caution

Care should taken not to damage the wiring harness of the vehicle to fit additional electrical accessories; which in-turn affects the 'CAN bus' system of the vehicle.

Anti-Lock Brake System (ABS)

Your motorcycle is fitted with an Anti-lock braking system (ABS) which is designed to prevent skidding and help riders to maintain steering control during emergency-stopping situation in dry or wet roads, loose gravels etc.

How does ABS work?

When a rider applies the brakes continuously as he detects a dangerous obstacle in dry or wet roads, loose gravels etc. thus transmitting excessive brake force to the wheel. This excessive force may cause the wheel to stop spinning and leads to loss of grip. With no firm contact between the tire's contact patch and the road surface, the bike becomes unstable and a crash is imminent.

The slipping wheels on a riding surface results in losing control of whole motorcycle which usually occurs in fraction of a second. Restoring traction while keeping the bike balanced is only a result of luck, or extreme training, as is the case of professional stunt riders who drift. Preventing the wheels from slipping due to excessive braking force compensates losing control and help the rider to maneuver the vehicle and to avoid accidents.

So what the ABS does is actually limiting the braking force exerted by the rider by regulating the brake pressure and keep the wheel spinning. Once the imminence of the locking (and therefore skidding) is avoided, the system re-applies the maximum braking force until the next skid is anticipated. By limiting the max force of the braking maneuver, the ABS systems practically allow riders to use the greatest stopping force possible without locking the wheels.

How does the ABS understands the wheel locking?

The ABS uses continuous wheel speed monitoring system; wheel speed sensors and toner rings (pulsar rings) and a Hydraulic Electronic Control Unit (HECU).

During normal operation the ABS works similar to a normal brake, but functions only when the wheel tends to lock up. The speed sensors fitted on both the wheels measures the rotational speed of the wheel, when the wheel speed reduces rapidly i.e. wheel tends to lock, the HECU modulates the pressure in the brake circuit and thereby prevents the wheel from locking.



How the irregular road surface affects the braking?

Humps and irregular surfaces of the road can cause the wheels to lose contact temporarily with the road surface; if this happens the braking force that can be transmitted to road surface is zero.

If the brakes are applied under these condition, the ABS has to reduce the braking force to ensure and maintain the directional stability when the wheels regains its contact with the road surface. At this instant the ABS must reduce the traction, so that the wheels will continue to rotate under all imaginable circumstances, because this is the precondition for ensuring directional stability. As soon as the actual circumstances arises, the system reacts instantly and adjusts braking force accordingly to achieve optimum braking.

Why does brake pedal / lever pulsate during brake application?

Vehicles fitted with ABS uses the conventional brake system during normal operation. But during hard stop the brake pedal / lever feels different, i.e., a rapid pulsation in the brake pedal / lever; This is absolutely normal.

It is not necessary to have this pulsation feel every time the brake is applied. Pulsations are felt only during wheel locking tendency, occurs due to the modulation of pressure in the brake circuit by HECU. Pulsation means that the vehicle is in limit. This pulsation feel also depends on the road condition.

Rear wheel lift

Under very severe and sudden deceleration, however, under certain circumstances it is possible that the ABS unit fitted in your vehicle will be unable to prevent the rear wheel from lifting clear of the ground and flip over.

Severe braking can cause the rear wheel to lift off the ground. When you brake, bear in mind that ABS control cannot always be relied on to prevent the rear wheel from lifting clear of the ground.

Warning

The ABS can apply and release the pressure in the brake circuit much faster than that rider can do with brake pedal / lever to avoid wheel locking, so there is no need to pump the brake, it requires only continuous application.

EMS a Glance

Engine Management System (EMS) of your motorcycle is a self-manipulative system that checks and regulates the proper functioning of all the operations carried out by the engine.

The EMS checks all the factors related to engine operations, i.e. speed of the engine, load, temperature, fuel consumption, etc. There are two major functions performed by the EMS, they are:-

- Provide a spark at the right time
- To meter fuel to the engine in the right quantity.

The EMS is comprised of several sensors and signals required for injection and ignition spark occurrence, and a sensor for information about the oxygen content in the exhaust and monitoring health of catalyst.

The Engine Control Unit or Electronic Control Unit (ECU) is a central part of the EMS, which is virtually the 'Brain' of an engine. It plays an important role of collecting, processing, analyzing and executing the data it receives from various sub-systems (sensors).

Furthermore, an ECU comprises of a computer which uses a microprocessor to process the inputs from various engine sensors in real-time.

Based on the data input, the ECU precisely calculates and delivers the ideal air-fuel mixture. It also regulates the idle speed of the engine and controls the correct delivery of both fuel and spark to the vehicle under various driving conditions.

Optimum functioning of the EMS assures maximum engine power, with lowest amount of exhaust emissions and the lowest fuel consumption. The EMS is also responsible for the smooth and efficient running of the motorcycle.

Emission Control

Source of Emissions

The combustion process of an engine produces carbon monoxide and hydrocarbons. Control of hydrocarbons is very important because under certain conditions, they react to form photochemical smog when subjected to sunlight.

Carbon monoxide does not react in the same way, but is toxic. TVS Motor Company Limited used various components to reduce carbon monoxide and hydrocarbons.

Exhaust emission control system

All the TVS motorcycles are tested in the factory for optimum fuel efficiency and lowest possible CO levels.

While adequate care is exercised at the factory to ensure that the emissions are within the limits, it is essential for the owner to always maintain the motorcycle in good condition by getting it periodically checked and serviced by TVS Motor Company Authorised Main Dealer so that the emission and fuel consumption levels are maintained as per norms.

Factors that may affect motorcycle emission

If the following symptoms are noticed in your motorcycle, have the vehicle inspected by TVS Motor Company Authorised Main Dealers.

- Abnormal jerk
- Difficult to start or engine gets off after starting. Improper idling
- Misfiring or backfiring during acceleration
- After-burning (back firing)
- Poor driveability and poor fuel economy.
- Noise due to sudden escape of gas during opening of fuel tank cap.

Crankcase emission control system

The engine of TVS Apache RTX is equipped with a closed crankcase ventilation system to prevent discharging crankcase emissions into the atmosphere. Blow-by gas is returned to the combustion chamber through the air cleaner and the throttle body.

Evaporative Emission Control System

The TVS Apache RTX is equipped with an evaporative emission control system which consists of a canister and associated piping. This system prevents the escape of fuel vapors from the throttle body and fuel tank.

Special Features of TVS Apache RTX

Ride by wire

Rider twists the accelerator, actuators in the electronic throttle body senses this movement and change the throttle opening accordingly. The movement of throttle alters air supply to the engine.

Throttle position sensor recognizes this change and sends a signal to ECU. Based on this signal, ECU calculates the exact amount of fuel required and fuel injection system injects fuel accordingly. Hence, engine receives correct amount of air-fuel mixture in every situation.

Slipper clutch

The 'Slipper Clutch' technology, accentuates the motorcycle's performance and with reduction in clutch force for quicker up shifts, enabling the rider to achieve better lap times. The technology also aims at ensuring rider safety in high speed downshifts, avoids wheel-hopping while cornering, and improves vehicle stability with the back-balance torque limiter effect.

Advantages of slipper clutch

- Avoids wheel hopping and provides increase in safety in high-speed downshifts and cornering, improved vehicle stability and balance - back torque limiter effect. Downshifts on muddy, dusty, snowy and wet surfaces is safe.
- Lower clutch operating force.
- Smooth downshifts operation and reduced gear shift force.
- Less bumpy ride in cornering- Slipper clutch absorbs engine braking force.
- No judder noise during sudden clutch launch.
- Reduced gearbox wear and less maintenance.

Quick shifter

Quick shifter helps in vehicle seamless clutch less gear shifting even in city speeds and traffic condition.

Quick shifter is tuned to enable seamless up and down shifts without clutch and throttle modulation.

Refer **page 40** for the details of the quick shifter system and its operation.

Glide Through Technology (GTT)

GTT is a feature for low speed urban riding which enables an extremely smooth and controlled ride.

With this feature, you can start moving the vehicle with a slow release of the clutch lever, without the throttle operation. This is a convenient feature while riding in heavy traffic. The requirement of the synchronization of the clutch lever and throttle grip is eliminated & engine stalling can be eliminated.

The maximum RPM with GTT feature without throttle (GTT rpm and speed given below is only indicative and actual may vary based on the driving conditions).

Gear position	GTT rpm	Speed km/h
1st gear	1900 rpm	12 km/h
2nd gear	2100 rpm	17 km/h
3rd gear	2100 rpm	22 km/h
4th gear	2200 rpm	27 km/h
5th gear	2200 rpm	32 km/h
6th gear	2200 rpm	37 km/h

Note

GTT works only in Urban and Rain mode and will not work in Tour and Rally mode.

Tyre Pressure Monitoring Sensor (TPMS)

The TPMS fitted on both front and rear tyres advertises the pressure value of the tyres to the connected TFT instrument cluster and the cluster will display the corresponding values on the widget if the widget is enabled.

There are four warning levels that will be displayed on the cluster's widget based the pressure level of the wheels.

Refer **page 85 & 90** for enabling the tyre pressure display widget and the details about pressure levels.

Note

TPMS is an optional accessory for TVS Apache RTX BTO. For top variant, it can be installed on payment basis. Contact any of our Authorised Premium Bike Dealers for installing the same.

If the TPMS is replaced by any chance, it should be configured to the instrument cluster of your vehicle to get the tyre pressure indication. Contact any of our Authorised Premium Bike Dealers for doing the needful.

* GTT rpm and Speed may vary based on the driving conditions

Straight line ABS system

The ABS has electronic sensors that detects the wheel locking before it happens. Therefore, when you apply brakes, ABS comes into action and alters the braking pressure to prevent the wheel locking. This process helps in maximising the braking performance of your bike.

Key features of straight line ABS:

- Improves safety.
- Assists in following the desired path while braking.
- Reduce risk of skidding or losing control in any surface.
- Increases the confidence during braking in all riding scenarios.

Linear traction control system

A linear traction control system (LTC / TCS) is designed to prevent loss of traction (i.e., wheel spin) in the rear wheel especially in low friction surfaces. It controls the engine torque and ensure optimal driving force on the road. It prevents the rear wheel from spinning during hard acceleration, and counteract the front wheel from leaving the ground.

Refer [page 73](#) for the details of the traction control system and its operation.

Key features of traction control system:

- Provides best acceleration without losing stability by rear wheel longitudinal slip control.
- Reduces the risk of uncontrollable large wheelie.
- It can be turned 'ON / OFF' and is adapted to the vehicle ride mode.

Cruise control system

Cruise control (CC) is a comfort function used to control vehicle speed and helps the rider to relax while riding on a open highway.

The rider is responsible for vehicle guidance, in particular lane guidance, adjusting the speed and driving style to match the traffic conditions. The rider can intervene at any time and takeover full control of vehicle operation.

Key features of cruise control system:

While touring or riding for long distances or cruising on highway, riders often like to maintain a constant speed and ride with comfort. However, changes in the road gradient, wind and other factors can make it difficult to constantly ride at a set speed using partial throttle. A cruise control system eliminates this inconvenience and makes the journey on a highway more comfortable and enjoyable. Minimises the riders fatigue. Rider can increase or decrease speeds as per his convenience.

However, it's important to understand that cruise control is not a safety feature and hence not a substitute for safe and responsible riding. Refer [page 32](#) for the details of the cruise control system and its operation.



Caution

All the features are rider assist features meant to enhance convenience and safety during rides. The features are not a replacement for rider control and will not prevent crashes in extreme conditions, the rider is always responsible for control and stability of the motorcycle.

Do not remove your hands from the handlebar while cruise control is active, as sudden impacts may cause the vehicle to lose its directional stability.



Note

During Engine / ABS malfunction, features functionality may be limited depending on the type of malfunction. It is strongly recommended to immediately visit any of our Authorised Premium Bike Dealers in case of any Engine / ABS malfunction.

Location of Parts - Vehicle RH Side View (Ref. Fig. 02)



- 1) Front wheel axle
- 2) Oil filter
- 3) Oil filler plug (ref. [page 148](#))
- 4) Oil level indicator (ref. [page 148](#))
- 5) Rear brake pedal (ref. [page 42](#))
- 6) Rider foot rest RH
- 7) Reservoir - Rear brake oil (ref. [page 152](#))
- 8) Pillion foot rest RH
- 9) Muffler assembly
- 10) Rear wheel axle
- 11) Disc plate rear
- 12) Pillion seat
- 13) Rider seat

Fig. 02

Location of Parts - Vehicle LH Side View (Ref. Fig. 03)



- 1) Disc plate front
- 2) Caliper assembly front
- 3) Gear shift pedal
(ref. [page 39](#))
- 4) Side stand
- 5) Rider foot rest LH
- 6) Rear shock absorber
(ref. [page 137](#))
- 7) Pillion foot rest LH
- 8) Chain guard
- 9) Seat lock
- 10) Pillion handle

Fig. 03

Warning

This section shows the position and function of the controls used to ride your motorcycle. Read this section carefully before riding the motorcycle.

Controls (ref. Fig. 04)

- 1) Instrument cluster (ref. [page 47](#))
- 2) Adjustable clutch lever (ref. [page 28](#))
- 3) Switch assembly LH (ref. [page 29](#))
- 4) Ignition cum steering lock (ref. [page 27](#))
- 5) Rear brake pedal (ref. [page 42](#))
- 6) Fuel tank cap (ref. [page 120](#))
- 7) Switch assembly RH (ref. [page 43](#))
- 8) Throttle twist grip (ref. [page 44](#))
- 9) Adjustable front brake lever (ref. [page 45](#))



Fig. 04

Vehicle Identification Number

All TVS motorcycles are provided with identification numbers for frame and engine. They are the only means of identifying your vehicle from others of the same model and type.

The frame identification number is engraved on the right of the steering head tube as shown (ref. Fig. 05).



Fig. 05

The engine identification number is engraved at the left side of engine on the magneto cover as shown (ref. Fig. 06).

Note

Do not remove the rust protection cover of the frame identification number from frame.



Fig. 06

Control Key

Your TVS Apache RTX comes with a pair of identical control keys. These keys are to operate ignition cum steering lock, fuel tank cap and seat lock.

A sticker ID (1) attached with keys has the identification number of keys. Please note down the identification number below for future reference (ref.

Fig. 07).

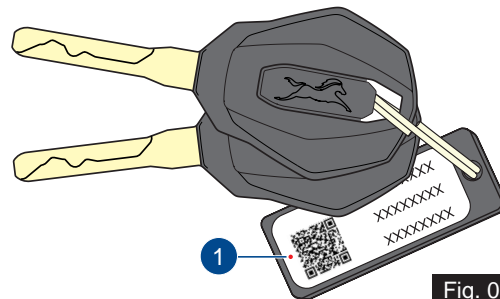

Fig. 07

Ignition cum Steering Lock

Ignition cum steering lock is located in front of fuel tank and has three positions (ref. Fig. 08):

- OFF (A): Disables lights and engine operation.
- ON (B): Enables lights and engine operation (with engine cut off switch is in run mode '⊙').
- LOCK (C): Steering is locked
 - To lock the steering, turn the handle bar all the way towards 'left' push the key in and turn it to 'LOCK' position.
 - Push and turn the key to 'OFF' or 'ON' position to unlock.

Note

Control key can't be taken out from the lock at position (B).

When you turn the ignition 'ON', the low beam + position lamp or DRL, tail lamp, and number plate lamp will automatically turn 'ON'.

The instrument cluster performs pre-check once the 'ignition lock' is turned 'ON'. Wait till the completion of pre-check.



Fig. 08

Caution

Always lock the steering while parking for safety. On level ground, always turn the handle bar towards left while locking the steering.

Ensure that, you do not keep the ignition 'ON' without starting the engine for a long time as battery might get drained because of headlamp, tail lamp and license plate.

Adjustable Clutch Lever (ref. Fig. 09)

Adjustable clutch lever (A) is located in the handle bar at LH side.

- Adjustable clutch lever is used to disengage clutch.
 - When the clutch is pressed, drive from the engine to the gearbox and the rear wheel is disengaged.



Fig. 09

Caution

Proper usage of clutch increases the life of engine component and prevent any damage to the transmission components of engine.

- Proper use of clutch lever is essential in all riding situations, especially while moving the vehicle from rest.

Note

Apply the clutch when starting the vehicle with gear engaged.



*Increase in engine rpm during acceleration, without increase in road speed indicates the clutch slip. A slipping clutch causes high fuel consumption and engine overheating. Refer **page 150** for clutch adjustment procedure.*

Use adjustable knobs in clutch lever to suit your finger reach to the clutch lever. Refer page 135 for adjustment procedure.

Switch Assembly LH

Switch assembly LH is located in the handle bar at LH side and has the following switches in it.

A) Switch beam control (ref. Fig. 10)

- Press the switch towards you '  ' to illuminate low beam.
- Press the switch away from you '  ' to illuminate high beam.
- When the head lamp is illuminated in high beam, the high beam indicator '  ' glows along with it.

In Base variant

The headlamp's low beam turns 'ON' automatically when the ignition is switched 'ON'. If the beam control switch is in high beam position, the headlamp's high beam also glows along with the low beam.

In Top variant

The DRL turns 'ON' automatically when the ignition is switched 'ON'. The high beam of the headlamp can be operated only after starting the engine.



Fig. 10

Warning

Use appropriate head lamp beam 'high / low' as per the traffic and road conditions for your safety and avoid inconvenience to other riders.

Note

In base variant, the headlamp is provided with front position and it glows along with the headlamp low beam when the ignition is switched 'ON'. But in top variant, the headlamp is provided with DRL lamp and its illumination level reduces and becomes a position lamp when the lamp operates in low beam.

B) Pass-by switch (ref. Fig. 11)

- Press the switch intermittently to flash the head lamp.
 - Flashing the head lamp high beam provides signal to the vehicles coming from opposite direction during overtakes.
 - If the high beam is flashed, the high beam indicator of instrument cluster '  ' also flashes along with it.

 **Note**

Pass by works only when the beam control switch is in low beam position.

Similarly, position lamp works only when switch is in 'Low' beam position.



Fig. 11

C) Hazard switch (ref. Fig. 12)



- Press the button '  ' to turn 'ON / OFF' the hazard lamps.
 - If the hazard indication is turned 'ON' while the turn signal indicators are active, the turn signal indicators will be suspended temporarily.
 - Turn signal indication will resume automatically once the hazard lamps are turned 'OFF' (if they were active before hazard lamp 'ON').
 - On activation of hazard lamps, both 'left' and 'right' turn signal indicators '  '  ', flashes.



Fig. 12

 Note

Hazard lamps can be switched 'ON / OFF' only by means of hazard switch.

The hazard switch functions only when the ignition is turned 'ON'. However, once activated, the hazard lamps will continue to operate for up to one hour even if the ignition is switched 'OFF' during their operation.

Avoid using hazard lamps while the engine is turned 'OFF' for prolonging time to avoid battery drain.

The hazard lamps will automatically turn off one hour after the ignition is switched off, once they have been activated.

D) Cruise control switch (ref. Fig. 13)

Cruise control switch has three operations in it.

Cruise control main switch operation:



- Momentary vertical press of cruise control switch knob turns 'ON / OFF' the cruise control.
 - When the cruise control is activated, the cruise control indicator of the instrument cluster '   ' glows along with it.



Fig. 13

Note

Cruise control function is not available in Rally mode of the vehicle.

Cruise control 'Set/-' switch operation:

Gentle push of cruise control switch knob towards 'Set/-' position activates the 'Set/-' switch.

- While the cruise control is turned 'ON' (cruise state), you can decrease already set cruise speed in the following manner:
 - In Sport Mode, long press (more than 1 secs) the knob to increase the vehicle speed by 5 km/h from set speed rounded to the nearest digit.
 - In Urban and Rain modes, long press (more than 1.5 secs) the knob to increase the vehicle speed by 5 km/h from set speed rounded to the nearest digit .
- While the cruise control is suspended (stand by mode), the 'Set/-' switch can be used as below:
 - Short press (less than 1 secs) the knob to set the current vehicle speed as the cruise control set speed.

Cruise control 'Res/+' switch operation:

Gentle push of cruise control switch knob towards 'Res/+' position activates the 'Res/+' switch.

- While cruise control is in standby mode, push the switch knob to 'Res/+' position to activate the cruise control.
 - In case cruise control set speed is stored previously, the vehicle will take the stored speed as cruise control set speed.

Note

Rider has to be above the minimum speed of the respective gears to resume the speed.

- In case cruise control set speed is not stored previously, the system takes current vehicle speed as cruise control set speed.

Conditions for turn 'ON' cruise control:

Cruise control can be switched 'ON' only when the following speed limit conditions are met at respective gear positions.

Gear Position	1st	2nd	3rd	4th	5th	6th
Minimum set speed (km/h)	20	25	30	35	40	45
Maximum set speed (km/h)	120 km/h					

To turn 'ON' the cruise control

- Press the cruise control switch when the vehicle speed is more than the minimum allowable speed limit. This will turn 'ON' cruise control and set speed will happen simultaneously.
 - If the cruise control switch is pressed when the vehicle speed is lesser than the minimum allowable speed limit, the cruise control will enter into 'Standby mode' and you need press the switch to 'Set/-' position after crossing the minimum allowable speed limit to enable the cruise control.

Conditions for cruise control suspend / cancel

- According to the accelerator grip position of the vehicle, override operation will be detected by the system and cruise control will be suspended. Vehicle speed will come back to 'SET' speed value after releasing the throttle within 10 secs.
 - Cruise control will be canceled in case the override operation continues more than 10 secs.
- If the accelerator grip position is overclosed to the negative direction (accelerator blip function), cruise control will be canceled.
- According to the brake lever or pedal operation by the rider, the ABS system of the vehicle detects the braking intention and cancels the cruise control. The cruise control will not be allowed to activate till the brake input is present.
- While the cruise control is active, the rider can use the clutch lever for gear shifting. If the clutch is applied and released within 2 secs, the cruise control will be active. In case the clutch is kept in applied condition for more than 2 secs, cruise control will get canceled.
- Cruise control will be canceled if the engine kill switch is activated.

Do's and Dont's while cruise mode is engaged

- Avoid keeping foot on the brake pedal while riding. Any input from the brake pedal will opt out the vehicle from cruise mode.
- Gear shift operation during vehicle ride will not affect the cruise control unless the gear position is changed into neutral. If the gear is shifted to neutral position cruise control will be cancelled and not allowed to be activated.
- Once the cruise mode is suspended, engine braking could be engaged to confirm the rider on the manual ride activation, depending on APS position and engine rpm.

Note

The working rpm range of cruise control is 2700 to 8300 rpm. In case if the rpm range is below or above, downshift or upshift the gear respectively to match with it.

Brake and clutch should be pressed atleast once to enable cruise control after every ignition 'ON'.

Cruise control will not work when there is an active error in EMS or ABS system of the vehicle.

Cruise control will be activated only when the vehicle is in 1st to 6th gear. It will not get activated in neutral gear.

 **Note**

Cruise control set speed is reset at every ignition 'OFF / ON' cycle or every cruise control main switch 'OFF / ON' cycle. The 'SET' target speed will get as long as the ignition and cruise control main switch is kept 'ON'.

In the same key 'ON' cycle if there is no previous set speed then if 'Res/+' is pressed, the current speed is set as cruise speed.

Ride mode change is not allowed during cruise.

Cruise control will not work if the 'Traction Control' is turned 'OFF'.

E) Control switches (ref. Fig. 14)

(e1) 'ENT' button (ref. Fig. 14)

- Press the button (e1) for selecting the menu display (Ride Mode, Trip Details, My Vehicle, Preferences).
- Press the button (e1) to enter / select.
- Press the button (e1) to accept an incoming call.

(e2) 'UP' button (ref. Fig. 14)

- Press the button (e2) directly from the home screen to toggle the ride modes.
- Press the (e2) button for changing the current selection.

(e3) 'DOWN' button (ref. Fig. 14)

- Press the button (e3) changing the current selection.

(e4) 'RETURN' button (ref. Fig. 14)

- Press the button (e4) to exit the current menu and go back to the previous menu.
- Press the button (e4) to reject an incoming call.
- Long press the button (e4) to return home screen from any menu.
- Press the button (e4) from home screen to control GoPro** in the preselected menu.



Fig. 14

Warning

Display setting to be done only when the motorcycle is stationary. Never operate the control switches while riding the motorcycle for safety.

Usage of the control switches while riding, should be avoided for a safe ride.

GoPro can be controlled from home screen when call is not active.

*** Applicable for specific variants only*

Based on different states, the menu buttons have different operation as shown in image



F) Switch turn signal (ref. Fig. 15)

- Push the switch towards ' ← ' to flash LH side turn signal lamps and towards ' → ' to flash RH side turn signal lamps.
- Push the switch 'IN' to cancel.
 - When the 'left' or 'right' side turn signal lamps are activated, respective turn signal indicator ' ← ' ' → ' flashes along with it in the instrument cluster.

G) Switch horn (ref. Fig. 15)

- Press the switch ' 📄 ' to blow horn.

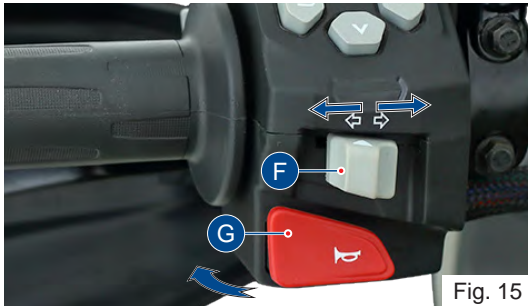

Gear shift pedal (ref. Fig. 16)

This motorcycle is equipped with a 6 speed constant mesh transmission.

- To select the required gear or to bring the vehicle to neutral, a gear shift lever (A) is provided and it is located on the LH side of the vehicle.
- To engage the 1st gear and to down shift the gear press the pedal down.
- To engage the 2nd, 3rd, 4th, 5th and 6th gear, lift the pedal upwards.
 - Each time you move the pedal you will be engaging the next gear.

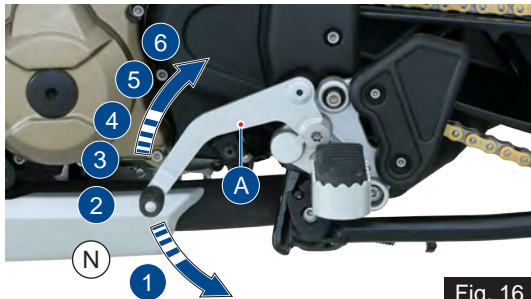



Fig. 16

- Gear shift pedal returns to its position (centre position) automatically when released after shifting.
- Once the transmission is brought to neutral position, the neutral indicator ' 

Note

Apply the clutch when starting the vehicle with gear engaged.

Gear shift pedal position can be adjusted as per the convenience of the rider. Please visit your near by TVS Motor Company Authorised Main Dealer

Quick Shifter

Quick shifter senses the gear shifting force applied on the gear shift pedal by the rider and signals the Engine Control Unit (ECU). The ECU automatically increases / decreases the torque of engine for a pre-set time period to enable the shift gear without applying the clutch.

In 'Urban' mode

Upshifting condition:-

- While riding the vehicle at slow speed without applying the throttle, while the engine rpm is greater than 2800 rpm and when the engine temperature is 50 degree and above upshifting is possible.
- Gear upshift works only with open throttle. While shifting do not close or blip throttle.
- There will not be any delay between gear to gear change during upshifts with wide open throttle.
- During cruise control, upshifts can be done throughout the cruise speed.
- In manual traction control (MTC) intervention, upshift is possible at any friction surface (low to high) only with open throttle.

Downshifting condition:-

- Downshifting is possible without throttle opening above 2800 engine rpm on Urban mode.
- During 2nd to 1st downshift quick shift function will not work.
- During cruise control downshift can be done throughout the cruise speed.
- In manual traction control (MTC) intervention downshift is possible at any friction surface.

In 'Rally' mode

Upshifting condition:-

- Upshifting of gear is possible only in throttle opening condition and engine rpm is above 3000 rpm from cold engine temperature. Do not close or blip throttle during gear shifting.
- There will not be any delay in power feel between gear to gear change during upshifts with wide open throttle.



Caution

The QSS is very sensitive to improve your joy of ride. Avoid keeping foot on the gear lever while riding. Any input from the gear lever will result in upshift or downshift of gear.

- During cruise control, upshifts can be done throughout the cruise speed.
- In manual traction control (MTC), upshift is possible at any friction surface (low to high) with open throttle only.

Downshifting condition:-

- Downshifting is possible with and without throttle opening at any engine rpm.
- During cruise control downshift can be done throughout the cruise speed.
- In manual traction control (MTC) downshift is possible at any friction surface.

Quickshifter working RPM:

Mode			
Urban	Rain	Tour	Rally
Above 2800 rpm		Above 3000 rpm	

 **Note**

For your flexibility of usage and customized ride experience, quick shifter can be turned 'ON / OFF' in menu. The last selection of quick shift settings is remembered during next ignition 'ON'.

Quick shifter will not work when the vehicle is in stationary condition or if the engine speed is less than 2800 rpm in Urban mode / 3000 rpm in Rally mode. After crossing above engine speed limits & vehicle in motion, clutch need not be applied for gear up / down shifting.

Upshift and downshift using quickshifter will be seamless when the engine temperature is above 50 degrees, this is to allow the oil to warm up and attain optimal viscosity for seamless gearshifts.

Rear Brake Pedal (ref. Fig. 17)

Rear brake lever (A) is located on the RH side of the vehicle.

- Push down the rear brake pedal with your right foot to operate the rear brake.
 - The system is operated by hydraulic and just need to push the lever gently.

Note

Front brake lever and rear brake pedal pulsates during the hard application of brake which is normal. This pulsation occurs because of ABS working.



Fig. 17

Switch Assembly RH

Switch assembly RH is located in the handle bar at RH side and has the following switches in it.

Switch electric starter with Engine Kill switch (ref. Fig. 18).

This motorcycle is provided with integrated switch electric starter with engine kill switch.

- The engine kill switch is used to switch off '⊗' the engine but to keep other DC system active.
- The ignition circuit is disabled, preventing the engine from being started. To restart the engine, return the switch to the '⊙' position.
- To start the engine keep the switch in '⊕' position, Ensure the transmission is in neutral or else press the clutch lever before engaging the starter switch.

⚠ Warning

Do not operate the kill switch when riding else you may fall due to rear wheel locking.

This switch is mainly intended for use in emergencies when you need to stop the engine quickly.



Fig. 18

👁 Note

If the electric starter switch is pressed more than 3 seconds continuously, the starter motor gets disabled automatically and will not crank the engine. The motor cranks the engine only after 1 second or if the switch is released and repressed again.

Note

Please remember that the electric starter function will work only when the throttle opening is less than 30%.

Release the electric starter switch immediately after engine starts.

Starter switch will not work if it is pressed when the engine is running.

It is possible to start the vehicle with the side stand ON and gear box in neutral. When starting the bike with the gear engaged, apply the clutch (the side stand must be up in this case. If the side stand is in ON position, after vehicle start engine stops while changing the gear from neutral).

Throttle Twist Grip (ref. Fig. 19)

Throttle twist grip (A) is located in the handle bar at RH side.

- Twisting the grip opens the throttle.
 - Throttle grip spring back to the initial position (idling speed) when released.

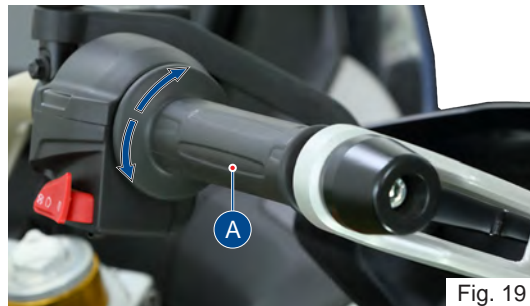

Fig. 19

Adjustable Front Brake Lever (ref. Fig. 20)

Adjustable Front brake lever (A) is located in the handle bar at RH side.

- Pull the lever towards the throttle twist grip to operate the front brake.
 - The system is operated by hydraulic and just need to press the lever gently.



Fig. 20

Note

Use adjustable knobs in the brake lever to suit your finger reach to the brake lever. Refer **page 135** for adjustment procedure.

Connected TFT Instrument Cluster Key Features (ref. Fig. 21)

- Your motorcycle is fitted with a 5" TFT instrument cluster.
- It has an advanced UI / UX design for TFT screen with cognitive ergonomics.
- The cluster has 4 different themes for 4 different ride modes in Light & Dark modes which give you a rich user experience.
- The TFT cluster in combination with infotainment switch enables you on-the-go mode selection.
- In-built photo-sensor helps to automatically adjust the brightness and change the display theme between Light and Dark if it is in AUTO.
- User alerts are made easy and effective with warnings and messages on the screen.
- Layout, font size, colors and themes enable quick and easy data access.



Warning

Risk of accident through the use of integrated information systems and communication devices during the journey.

Operate these systems or devices only if the traffic situation allows. If necessary, stop and operate the system or devices at a standstill.

TFT Instrument Cluster

Instrument cluster will be activated once the 'ignition lock' is turned 'ON'.

All segments and tell-tale indicators glow for 2 seconds on activation of instrument cluster for checking and ensuring the proper working of segments and indicators.









Fig. 22

Following are the features of instrument cluster:





Warning and indicator lights (ref. Fig. 22)

- | | | |
|-------------------------------|-------------------------------|------------------------------|
| A) Photometric sensor | B) Turn signal indicator RH | C) EMS malfunction indicator |
| D) High beam indicator | E) ABS indicator | F) Cruise control indicator |
| G) Turn signal indicator LH | H) Low fuel warning indicator | I) Neutral indicator |
| J) Traction control indicator | | |

1. Warning and Indicator Lights (ref. Fig. 22)

Symbol	Lights	Meaning
	A. Photometric sensor	Adjusts the TFT brightness and tell tale indicators brightness automatically as per day and night conditions.
	B. Turn signal indicator RH	Flashes when the right side turn signal indication is activated.
	C. EMS Malfunction indicator	Glowes when any problem is detected in the engine management system causing vehicle to exceed on-board diagnostic emission threshold.*
	D. High beam indicator	Glowes when the head lamp high beam is activated
	E. ABS indicator	Flashes when the ABS self-diagnostic not completed / not yet initiated - Ride the vehicle more than 6 km/h speed. Glowes continuously when the ABS has an error or malfunction.* Goes OFF after 6 km/h speed - ABS is active and ready to use.
	F. Cruise control indicator	Will be 'OFF' when cruise control is disabled and having any error in the system. Glowes in orange when cruise control is enabled and in standby. Glowes in green when cruise control is in cruise / active / suspend / override and during rider take control.

* Contact TVS Motor Company Limited Authorised Main Dealer

Symbol	Lights	Meaning
	G. Turn signal indicator LH	Flashes when the left side turn signal indication is activated.
	H. Low fuel warning indicator	Glows when the fuel level in the tank reaches to minimum safe level or any malfunction in the fuel level sensor.*
	I. Neutral indicator	Glows when the vehicle is in neutral condition.
	J. Traction control indicator	Glows when there is a traction control fault or disabled by rider. Blinks when initializing and when active.

Note

The vehicle automatically goes to reduced performance mode if the engine temperature is very high.

* Contact TVS Motor Company Limited Authorised Main Dealer

2) TFT Multifunction Display (ref. Fig. 23)

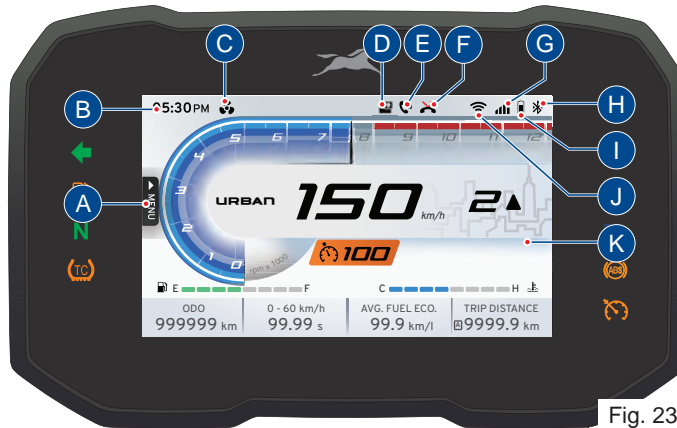
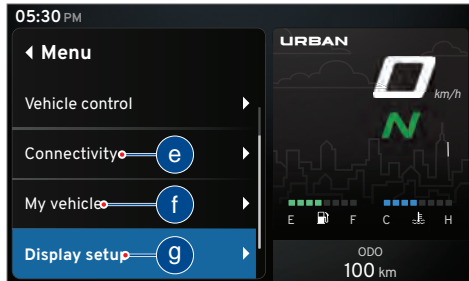
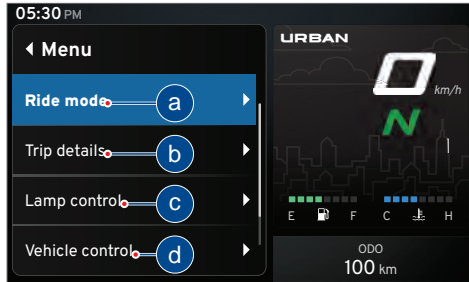

Fig. 23

- A) Menu function
- B) Clock
- C) Cooling fan status
- D) GoPro connected
- E) Ongoing call indication
- F) Missed call indication
- G) Mobile signal strength
- H) Bluetooth connectivity indication
- I) Mobile battery status
- J) Wi-fi connectivity status
- K) Multifunction display

A) Menu indication



TVS Apache RTX's connected instrument TFT cluster offers you different menus to choose. Sequence of the menu; their selection and their working are explained in the following pages. Following are the main menus available under the menu function

- a) Ride mode
- b) Trip details
- c) Lamp control
- d) Vehicle control
- e) Connectivity
- f) My vehicle
- g) Display setup

To select the required menu:

- Keep the vehicle stationary and switch 'ON' the ignition.

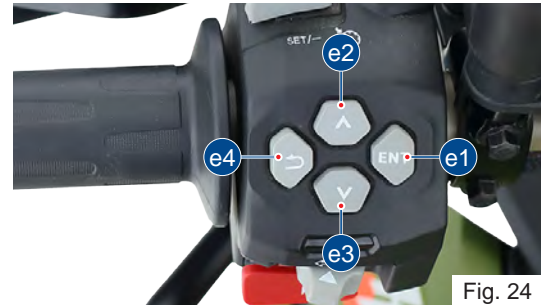

Fig. 24

- After the self-check of the instrument cluster, press the 'ENT' (e1) button to enter the menu function (ref. Fig. 24).
- Navigate using 'Up' (e2) and 'Down' (e3) arrow.
- Press the 'ENT' button again after selecting the required menu.
- Press the 'Return' button (e4) to come out of menu selection window.

Note

For your safety, it is not allowed to navigate through the menu which is not of high importance while riding the bike. Once your vehicle reaches above 5 km/h speed, the menu functions like 'Connectivity, My vehicle and Display setup' get locked.

a) Ride mode

TVS Apache RTX is made to operate in four different ride modes namely:

- a1. Urban**
- a2. Rain**
- a3. Tour**
- a4. Rally**

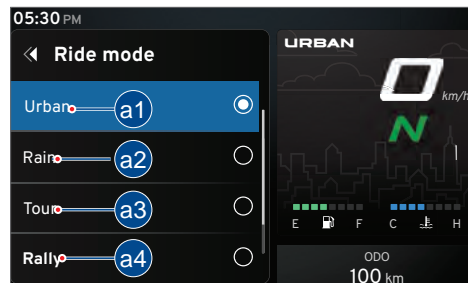

Note

The above mode changes are possible only when the throttle is fully closed.

Ride Mode

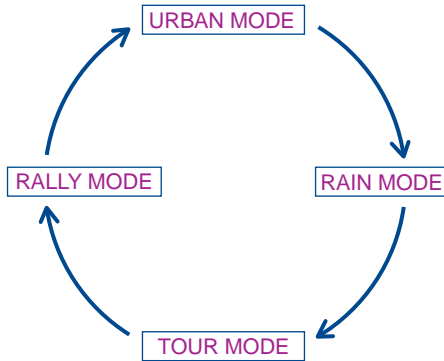

 **Caution**

In case any fault is detected with respect to the ride mode change in the 'EMS' or 'ABS' system, then your motorcycle will operate only in the 'URBAN' mode.

 **Note**

On ignition 'OFF' and 'ON' the previously displayed mode will be retained in display of the connected TFT instrument cluster.

In order to improve performance, consistency and durability of your motorcycle, rider is advised to ride with reduced rpm during running-in period (1000 km).

Ride modes - performance

Ride mode	Engine performance	ABS performance	Remarks
a1. Urban mode	Speed is limited to 130 km/h Linear acceleration and deceleration Better crawling Optimal idling speed	Mild pulsation feel on levers Good braking response Good braking performance Good safety and stability Good rear lift protection (RLP) Optimal vehicle drive feel	Rider are advised to ride the vehicle in reduced RPM during running-in period, till the ODO meter reaches 1000 kms. Refer page 8 for details.
a2. Rain mode	Same as Urban mode	Strong pulsation feel on levers Reduced braking response Reduced braking performance Excellent safety and stability Excellent RLP Very less vehicle drive feel	
a3. Tour mode	Same as Rally mode	Same as Urban mode	
a4. Rally mode	Vehicle maximum speed tuned to the full potential of the engine/vehicle Tuned for maximum acceleration across all operating conditions Optimised deceleration and engine braking Engine speed is limited to 10400 rpm	Reduced pulsation feel on levers. Excellent braking response Excellent performance Acceptable safety and stability Reduced RLP - allowable up to its safety limit. Rear will become non- ABS.	

a1. Urban Mode

The 'URBAN' mode is available in two distinct themes: Dark and Light.

Dark theme



Light theme



Note

Please note that the top speed for 'URBAN' mode is limited to 130 km/h and also 'ABS' performance is tuned for 'URBAN' mode and will be different for other modes.

If you desire to ride your motorcycle at a speed higher than the above-mentioned value, ensure to change the ride mode to 'RALLY' or 'TOUR' mode. For further details, visit TVS Motor Company Authorised Main Dealer.

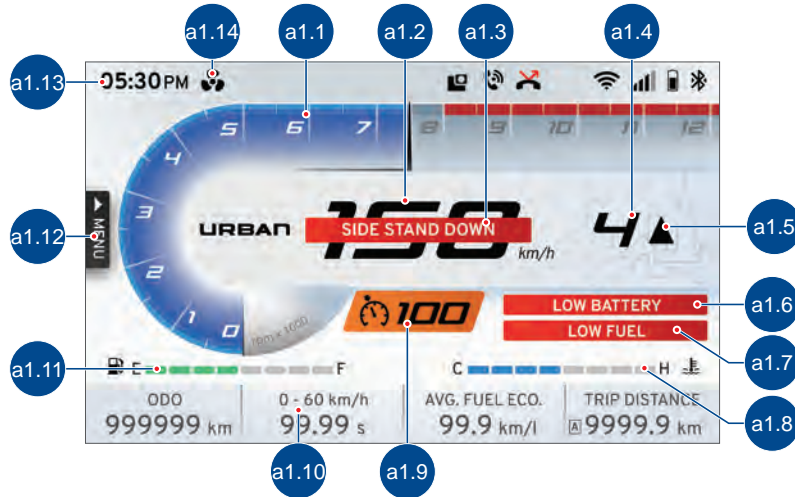

In 'URBAN' mode, the following features will be displayed on the instrument TFT cluster:

- | | | |
|-----------------------------------|------------------------------------|------------------------------------|
| a1.1 Dynamic engine rpm indicator | a1.6 Low battery warning indicator | a1.11 Fuel level indicator |
| a1.2 Speedometer | a1.7 Low fuel warning indicator | a1.12 Menu indicator |
| a1.3 Side stand warning indicator | a1.8 Coolant temperature indicator | a1.13 Digital clock |
| a1.4 Gear position indicator | a1.9 Cruise control indicator | a1.14 Cooling fan status indicator |
| a1.5 Gear shift indicator | a1.10 Widgets indicator | |

a1.1 Dynamic engine rpm indicator

- Digital band (a1.1) indicates the engine rpm in multiples of 1000 rpm.
- Digital bands are indicated in blue and red band based on the engine coolant temperature. Refer below table for details.



Engine Coolant temperature	Blue band RPM range	Red band RPM range
-25°C to 20°C	0 - 5000 rpm	5000 - 12000 rpm
20°C to 60°C	0 - 7000 rpm	7000 - 12000 rpm
60°C to 120°C	0 - 9500 rpm	9500 - 12000 rpm
Above 120°C	Engine will cut-off.	

a1.2 Speedometer



- Displays the road speed in km/h (a1.2) (in India).

a1.3 Side stand warning indicator

- If the side stand is 'ON', the text message 'SIDE STAND DOWN' (a1.3) will be displayed in connected TFT instrument cluster.



Note

The vehicle will start in side stand in neutral gear but not in other gears. The vehicle will also 'switch off' if the side stand is 'ON' and gear is changed from neutral to gear.

In case of any errors in side stand switch - side stand indication will be always shown as 'SIDE STAND ERROR' in the instrument cluster immaterial of side stand status.

In the event of any unfortunate accident, if the side stand / side stand switch has been damaged, the signal can be bypassed by disconnecting the side stand switch coupler.

a1.4 Gear position indicator

- Gear position indicator (a1.4) indicates vehicle's present gear position and neutral condition. Gear position indication displays "--" if there is any problem in the system. Take the vehicle to TVS Motor Company Authorised Main Dealer.



a1.5 Gear shift indicator

- The gear shift indicator notifies the rider to shift up or down based on the engine's RPM and the selected ride mode. An upward arrow signals a shift to a higher gear, while a downward arrow indicates a shift to a lower gear.



a1.6 Low battery warning indicator

- Low battery warning indicator (a1.5) appear when the battery charge is too low. Get the battery checked at TVS Motor Company Authorised Main Dealer.

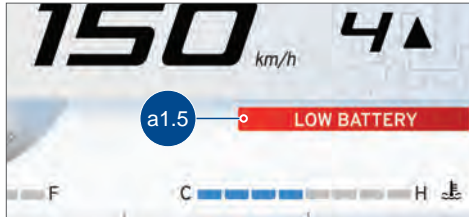

- When this warning message occurs take the vehicle immediately to TVS Motor Company Authorised Main Dealer.

 **Caution**

If this warning message occurs the vehicle can be ridden for approx. 25 kms or 40 minutes only (which depends on the state or health of the battery).

a1.7 Low fuel warning indicator

- Low fuel warning indicator (a1.6) is a safety indicator to caution you to fill the petrol as soon as possible. Minimum 2.2 liters of petrol will be available when this indicator comes 'ON'.

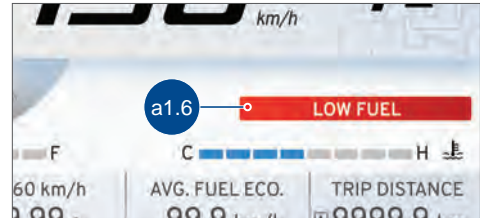

 **Caution**

When the low fuel warning indicator glows fill fuel immediately to avoid engine 'OFF / Damage' to fuel pump which leads to replacement of pump without warranty.

a1.8 Coolant temperature indicator

- Digital bars (a1.7) indicates the engine coolant temperature.



- The coolant temperature indicator displays more than six bars if there is any problem in the cooling system.



- In case of any error in input system, all the bars coolant temp indicator flashes.
- Take the vehicle to TVS Motor Company Authorised Main Dealer for further diagnosis.

Note

The vehicle automatically goes to reduced performance mode if the engine temperature is very high.

a1.9 Cruise control indicator

- Cruise control indicator (a1.8) will be 'ON' and glows in green colour when the cruise is control is in cruise mode / active, in suspend / override condition and when the rider takes control.
 - Glows in amber colour when the cruise control in enabled and in standby mode.



Note

Cruise control indicator will be 'OFF' when it is not active and if there is an error in the system.

Cruise control will not work in 'RALLY' mode. An error message "CRUISE CONTROL IS NOT AVAILABLE" message will be displayed if the cruise is turned 'ON' in 'RALLY' mode.

a1.10 Widgets indicator

- Widgets (a1.9) indicates the (viz. ODO, IMI, Avg. Speed, Avg. Mileage etc.) can be used to display live feeds in the home screen of your TFT instrument cluster.



Note

To change the widgets in the home screen of your TFT instrument cluster (ref. **page 85**).

a1.11 Fuel level indicator

- Digital bars (a1.10) indicates the approximate quantity of fuel available in the tank.



- There are eight bars to indicate the quantity fuel.
- All the eight bars will be displayed when the fuel level in the tank reaches approximately 10.2 liters.



- When the fuel level reduces to 5 liters (approx.) the indicator displays only five bars.



- If the fuel level is less than 2.2 liters, the low fuel indicator '🛢️' starts glowing.
- If the fuel level reaches to minimum safe level ie. lesser than 2 liter approximately, fuel level indicator displays a single bar.
- Fill fuel (ref. [page 120](#)) immediately.



Note

Please ensure that the fuel bar indication in cluster is greater than 1 bar always. It is unsafe to ride with 1 bar or less.

Incase of any error in input system, all the bars of fuel level indicator flashes and low fuel warning indicator turns ON. Contact nearest TVS Motor Company Authorised Main Dealer incase any of these problems are noticed.

Warning

If the vehicle runs with very less fuel it will result in improper engine operation or shutdown due to lack of fuel which may result in accident.

Caution

Do not run the fuel tank dry to avoid failure of fuel pump and other consequential damages if any.

a1.12 Menu indicator

- Menu indicator indicates the different menus when 'ENT' button is pressed. Sequence of the menu; their selection and their working are explained in [page 51](#).



a1.13 Digital clock

- Indicates the timing either in 12 hour format or in 24 hour format based on the setting. Refer [page 95](#) for setting the clock timing.

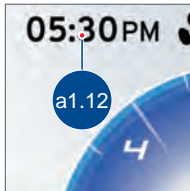

a2. Rain Mode

The 'RAIN' mode is available in two distinct themes: Dark and Light.

Dark theme



Light theme



Note

All the features are similar like 'URBAN' mode. Refer 'URBAN' mode for the detailed explanation.

Although, vehicle performance will be changed due to the change in ride mode. In 'RAIN' mode top speed of the vehicle is limited to 130 km/h.

If you desire to ride your motorcycle at a speed higher than the above-mentioned value, ensure to change the ride mode to 'RALLY' or 'TOUR' mode. For further details visit TVS Motor Company Authorised Main Dealer.

a3. Rally Mode

The 'RALLY' mode is available in two distinct themes: Dark and Light.

Dark theme



Light theme

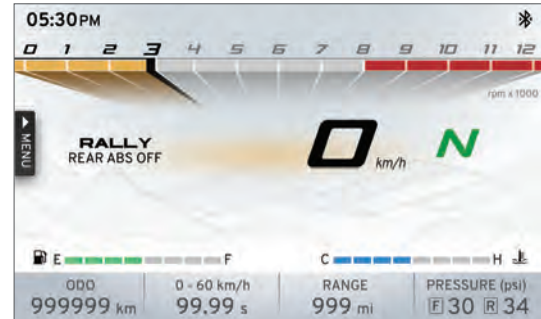

Note

All the features are similar like 'URBAN' mode with some notable changes in the UI (graphics). Refer 'URBAN' mode for the detailed explanation. Although, vehicle performance will be changed due to the change in ride mode.

In 'RALLY' mode top speed of the vehicle is limited to 139 km/h and rear ABS will be 'OFF'.

a4. Tour Mode

The 'TOUR' mode is available in two distinct themes: Dark and Light.

Dark theme



Light theme

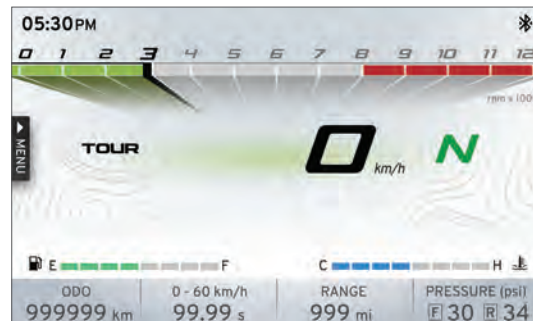

Note

All the features are similar like 'URBAN' mode with some notable changes in the UI (graphics). Refer 'URBAN' mode for the detailed explanation. Although, vehicle performance will be changed due to the change in ride mode.

In 'TOUR' mode top speed of the vehicle is limited to 139 km/h.

b) Trip Details

- 'Trip details' menu is used to record and display the individual trip's details such as distance, time speed, fuel economy etc.

To enter the 'Trip details' menu:

- Keep the vehicle stationary and switch 'ON' the ignition. After the self-check, navigate to 'Trip Details' in menu and press the 'ENT' (e1) button (ref. Fig. 24).

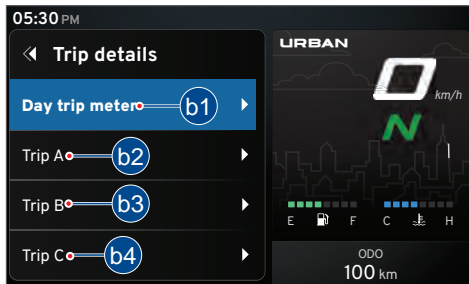

- Totally 4 trip meters namely 'Day trip meter', 'Trip A', 'Trip B', and 'Trip C' are available.
 - After entering the 'Trip details' menu, navigate using 'Up' (e2) and 'Down' (e3) arrow.

- Press the 'ENT' button after selecting the required 'Trip' mode (Day trip meter, trip A, trip B or trip C).
- 'Day trip meter' records the trip details such as Trip distance, Trip time, Avg. speed, Top speed, Fuel consumed and Average fuel economy on that particular day.

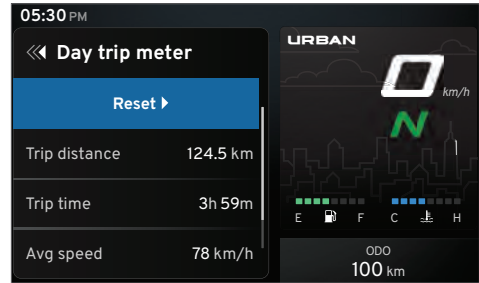

Note

'Trip' meter can be added as a widget to see the 'Trip ODO' details. Refer **page 85** for the detail procedure for adding the widgets.

- The values will get reset in case of change in date.
- You can reset it whenever you wish to record the data for new journey. To reset:

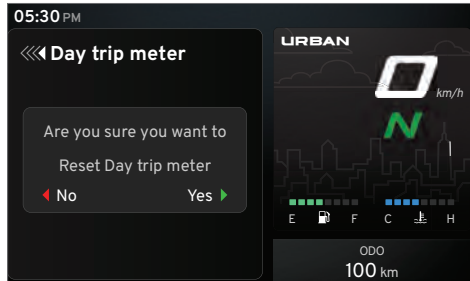

- Select the 'Reset' option at the top of the window and press the 'ENT' button.
- On pressing the 'ENT' button, a window gets popped up requesting your confirmation to reset.
- Once again press the 'ENT' button to reset the particular 'Trip' details or else press the 'Return' (e4) button to come back to main menu.

- On selecting the particular trip mode, the trip details such as Trip distance, Trip time, Avg. speed, Top speed, Fuel consumed and Average fuel economy of individual journeys will be displayed.

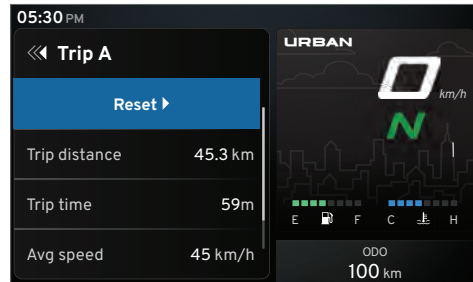

- You can reset the 'Trip details' whenever you wish to record the data for new journey in the following manner:
 - Select the 'Reset' option at the top of the window and press the 'ENT' button.
 - On pressing the 'ENT' button, a window gets popped up requesting your confirmation to reset.

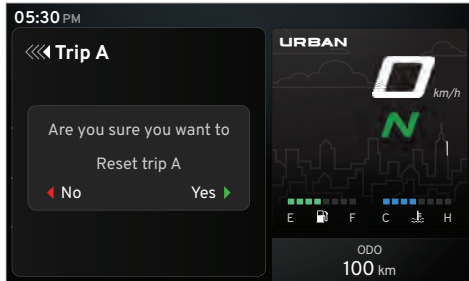

- Once again press the 'ENT' button to reset the particular 'Trip' details or else press the 'Return' (e4) button to come back to main menu.

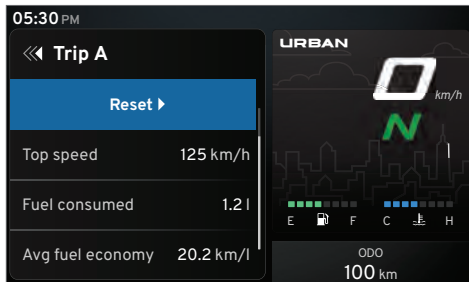

c) Lamp control**

- The control functions for the headlamp and welcome lamps can be found under the 'Lamp Control' menu.

To enter the 'Lamp control' menu:

- Keep the vehicle stationary and switch 'ON' the ignition. After the self-check, navigate to 'Lamp control' in menu and press the 'ENT' (e1) button (ref. Fig. 24).
- The following are the control functions available under the 'Lamp control' menu.

- C1. Headlamp control**
- C3. Take me home**

- C2. Headlamp intensity**
- C4. Welcome lamps**

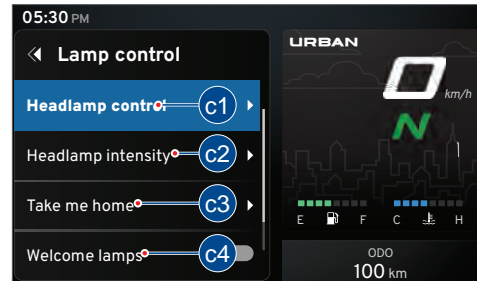

** Applicable for specific variants only

c1. Headlamp control

- After entering the 'Lamp control' menu, select the 'Headlamp control' option using 'Up' (e2) or 'Down' (e3) arrow (**ref. Fig. 24**).
- Once the 'Headlamp control' option is selected, press the 'ENT' (e1) button.

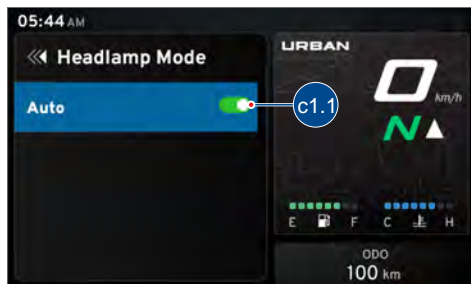

- When the 'Auto' option is turned 'ON', the headlamp automatically switches between DRL and low beam based on the ambient light conditions.
- When the 'Auto' option is turned 'OFF', the headlamp operates by default in DRL mode when ignition is turned 'ON' and until engine is started.

- In 'Headlamp control', the following headlamp controlling option is available to control the headlamp functions.

c1.1 Auto

C2. Headlamp intensity

- After entering the 'Lamp control' menu, select the 'Headlamp intensity' option using 'Up' (e2) or 'Down' (e3) arrow (ref. Fig. 24).
- Once the 'Headlamp intensity' option is selected, press the 'ENT' (e1) button.



- When the 'Auto' option is turned 'ON', the headlamp intensity adjusts automatically based on the vehicle's speed.
- When the option is turned to 'OFF', the headlamp glows with a preset intensity.

- In 'Headlamp intensity', the following headlamp controlling options are available to control the headlamp functions.

c2.1 Auto

c3. Take me home

- After entering the 'Lamp control' menu, select the 'Take me home' option using 'Up' (e2) or 'Down' (e3) arrow (ref. Fig. 24).
- Once the 'Take me home' option is selected, press the 'ENT' (e1) button.

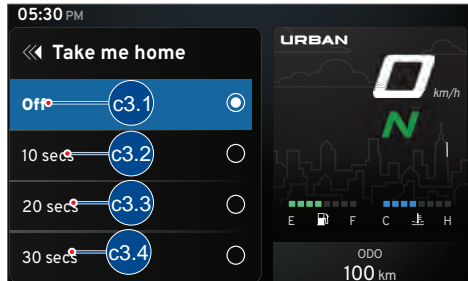

- Using 'Up' (e2) or 'Down' (e3) arrow either you can alter the duration of headlamp 'ON' timing or you can switch 'OFF' the take me home function.

Note

The headlamp stays 'ON' for selected time after ignition is turned 'OFF'. Keeping the headlamp turned 'ON' for longer time after ignition 'OFF' may drain battery.

c4. Welcome lamps

- After entering the 'Lamp control' menu, select the 'Welcome lamps' option using 'Up' (e2) or 'Down' (e3) arrow (ref. Fig. 24).
- Once the 'Welcome lamp' option is selected, press the 'ENT' (e1) button to enable or disable.

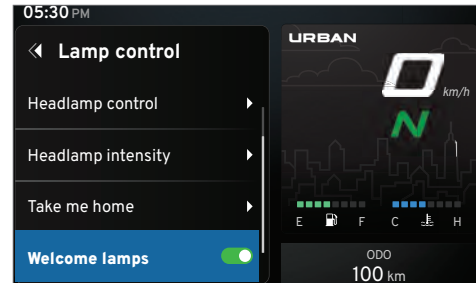

- When 'Welcome lamp' is enabled there will be DRL animation during every ignition 'ON' and 'OFF'.

d) Vehicle control

- The control functions for the traction control, quick shift control etc. can be found under the 'Vehicle Control' menu.

To enter the 'Vehicle control' menu:

- Keep the vehicle stationary and switch 'ON' the ignition. After the self-check, navigate to 'Vehicle control' in menu and press the 'ENT' (e1) button (ref. Fig. 24).
- The following are the control functions available under the 'vehicle control' menu.

- d1. Traction control** **d2. Quick shift control**
d3. Tyre pressure

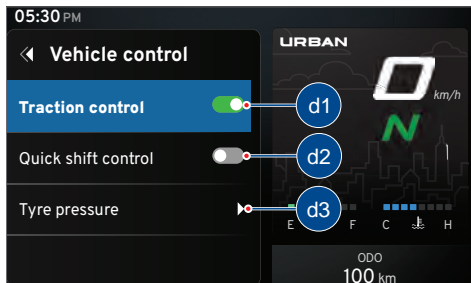

To enable or disable Traction control (d1) and Quick shift control (d2)**

- Navigate using 'Up' (e2) and 'Down' (e3) arrow (ref. Fig. 24).

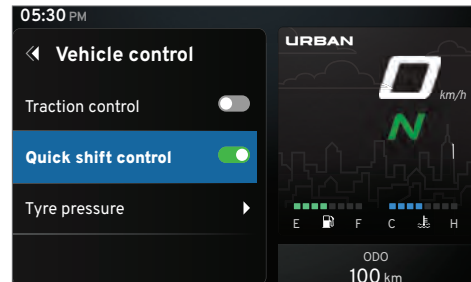

- Press the 'ENT' button to enable or disable the required option.
- Press the 'Return' button to come back to menu display.

** Applicable for specific variants only

Key functions of Traction control

- Control engine torque and ensure optimal driving force on the road.
- Prevent the rear wheel from spinning during acceleration, and counteract the front wheel from leaving the ground.
- Regulate the maximum engine torque, when the rear wheel spins during vigorous acceleration.
- Best acceleration with keeping stability by proper wheel longitudinal slip control at rear.
- Mitigation for uncontrollable large Wheelie by engine torque down.

d3. Tyre pressure**

- After entering the 'Vehicle control' menu, select the 'Tyre pressure' option using 'Up' (e2) or 'Down' (e3) arrow (ref. Fig. 24).
- Once the 'Tyre pressure' option is selected, press the 'ENT' (e1) button.
- In tyre pressure option the cluster will display tyre pressure of both wheels.

** Applicable for specific variants only

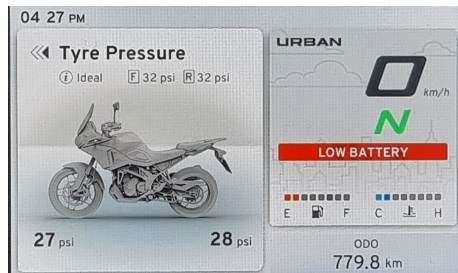

- The TFT instrument cluster will display the followings.

Low pressure **High pressure**
Critical pressure (Very Low/ Very High)
TPMS battery low

- It is advised to drive with indicated ideal tyre pressure to maintain safety, Fuel efficiency tyre life and comfort.

Note

In case malfunction warning visit TVS Motor Company Authorised Main Dealer.

e) Connectivity**

- 'Connectivity' menu is used for pairing your smart phones, go pro etc.

To enter the 'Connectivity' menu:

- Keep the vehicle stationary and switch 'ON' the ignition. After the self-check, navigate to 'Connectivity' in menu and press the 'ENT' (e1) button (ref. Fig. 24).
- The following are the control functions available under the 'Connectivity' menu.

**e1. Paired devices e2. Do not disturb
e3. GoPro**

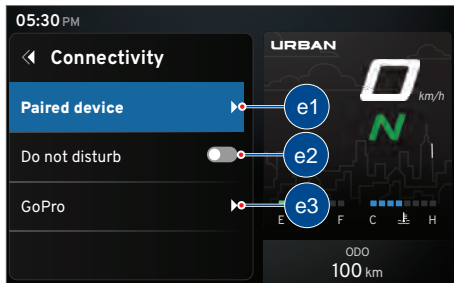

** Applicable for specific variants only

e1. Paired devices

- After entering the 'Connectivity' menu, select the 'Paired devices' option using 'Up' (e2) or 'Down' (e3) arrow (ref. Fig. 24).
- Once the 'Connectivity' option is selected, press the 'ENT' (e1) button.
- To remove the paired device from the TFT instrument cluster, press the 'ENT' button on the selected device name.



- In case there is no device connected to the TFT instrument cluster, the cluster displays the message 'You have not paired any device yet' as shown.

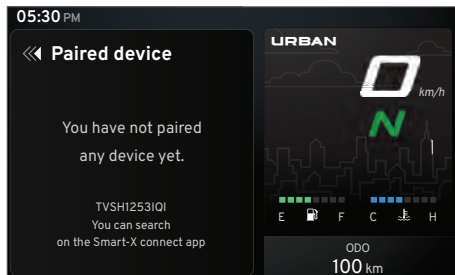

- To add new device to the TFT instrument cluster, navigate to the 'Paired device' tab and press the 'ENT' button. Refer [page 75](#) for the detailed procedure of pairing a new device. A new device can also be paired directly from Home screen by selecting device name in App.

e2. Do not disturb

- To enable or disable Do not disturb navigate to 'Do not disturb' in Connectivity menu, using 'Up' (e2) or 'Down' (e3) arrow ([ref. Fig. 24](#)).
- Once the 'Do not disturb' option is selected, press the 'ENT' (e1) button.

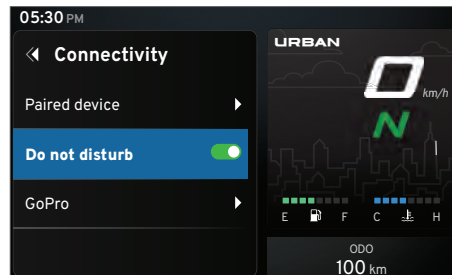

- Press the 'ENT' button to enable or disable the required option.
- Press the 'Return' button to come back to menu display.
- When do not disturb is enabled your TFT instrument cluster will not display any warning from your smart phone.

e3. GoPro

- After entering the 'Connectivity' menu, select the 'GoPro' option using 'Up' (e2) or 'Down' (e3) arrow (**ref. Fig. 24**).
- Once the 'GoPro' option is selected, press the 'ENT' (e1) button.



- The following sub menu functions are available under the 'GoPro' menu.

e3.1. Pair GoPro e3.2. GoPro Controls

- Select the 'Pair GoPro' option using 'Up' (e2) or 'Down' (e3) arrow to pair a new GoPro device or select the 'GoPro Controls' option to change GoPro device settings.



- When the 'Pair GoPro' option is selected and no nearby devices are detected, the cluster displays the message: 'No devices available for pairing,' as shown.

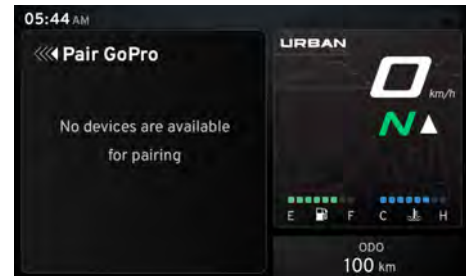

- The devices are detected nearby will be listed on the display as shown.

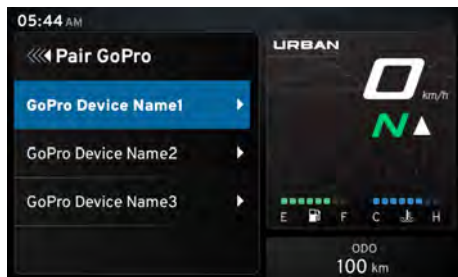

- Use the 'Up' (e2) or 'Down' (e3) arrows to select the desired device and press the 'ENT' button.
 - Upon pressing 'ENT', a confirmation screen will appear requesting your approval to connect.
 - Press 'ENT' again to confirm and establish the connection, or press the 'Return' (e4) button to cancel and return to the previous menu.



- After establishing the connection, a window pops up with the confirmation message 'GoPro Connected' as shown below:

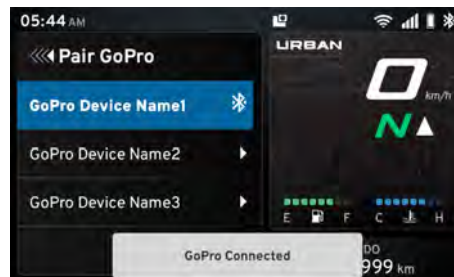

- To modify the GoPro device settings, navigate to the 'GoPro Controls' option using the 'Up' (e2) or 'Down' (e3) arrows, then press the 'ENT' button.

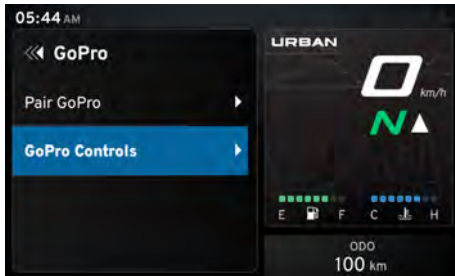

- The following are the control functions available under the 'GoPro controls' menu.

e3.3. Photo **e3.4. Burst photo**
e3.5. Timelapse **e3.6. Video**

- Using 'Up' or 'Down' arrow, select the required option and press the 'ENT' button.



Note

TVS Apache RTX 'GoPro' connectivity feature is compatible with only selected versions of 'GoPro'. 'GoPro 9' and onwards is recommended for experiencing the best of 'GoPro' connectivity. Connect 'GoPro' from remote device menu for 'GoPro 9'. For 'GoPro 11' or above, set device in Pro mode to connect your 'GoPro' from Instrument Cluster.

'GoPro' will get connect to only one device at a time (first device to connect gets priority) – For instance, if the 'GoPro' is connected to the cluster, it may not connect with 'GoPro' Quick App / Remote / Volta devices and vice versa. After every ignition cycle, 'GoPro' has to be manually connected from Instrument Cluster. It does not connect automatically.

f) My vehicle

- The My vehicle menu is to access Service information, few vehicle performance records, and personal documents stored in the memory can be found under the 'My vehicle' menu.

To enter the 'Vehicle control' menu:

- Keep the vehicle stationary and switch 'ON' the ignition. After the self-check, navigate to 'my vehicle' in menu and press the 'ENT' (e1) button (ref. Fig. 24).
- The following are the control functions available under the 'vehicle control' menu.

f1. Service

f2. Performance record

f3. Documents

f4. My apache

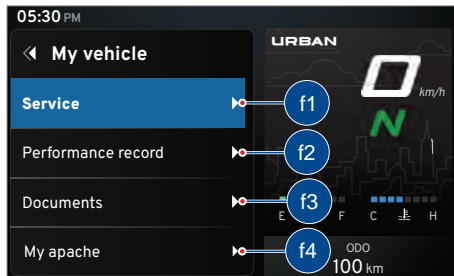

f1. Service

At the time of delivery of your TVS Apache RTX the service date and service kilometers will be registered in the instrument cluster of your vehicle by TVS Motor Company Authorised Premium Bike Dealers.

- After entering the 'My vehicle' menu, select the 'Service' option using 'Up' (e2) or 'Down' (e3) arrow (ref. Fig. 24).
- Once the 'Service' option is selected, press the 'ENT' (e1) button.

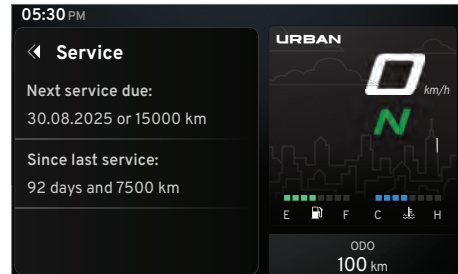

- Upcoming service date of your vehicle will be displayed in the service menu as shown.
- In addition to that, days and kilometers from last service will be also displayed.
 - Press the 'Return' button (e4) to come back to menu display.

Note

'SERVICE DUE' notification will pop-up on your cluster if your motorcycle is either 250 km ahead of the registered service kilometers or 7 days prior to the service date.

In case you fail to service your motorcycle within the prescribed date and kilometers, 'SERVICE OVERDUE' message will be displayed on the cluster.

f2. Performance record

Few of your vehicle's performance data are stored under 'Performance record' option for your reference. To view them:

- After entering the 'My vehicle' menu, select the 'Performance record' option using 'Up' (e2) or 'Down' (e3) arrow (**ref. Fig. 24**).
- Once the 'Performance record' option is selected, press the 'ENT' (e1) button.

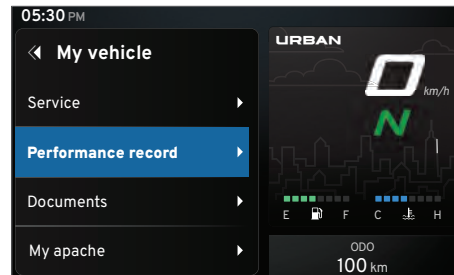

- The following options will be displayed under the 'Performance Record' tab, along with valve information:
 - ◆ Top speed
 - ◆ Avg speed
 - ◆ 0 - 60 km/h
 - ◆ Best mileage

- Once again press the 'ENT' button to reset the particular 'Trip' details or else press the 'Return' (e4) button to come back to main menu.

When performance record is reset, all the trip details will get erased.

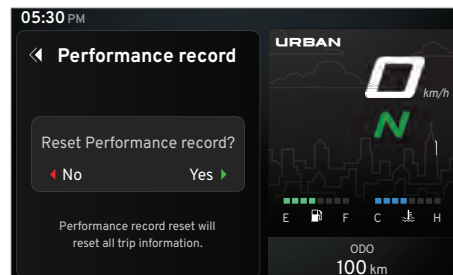
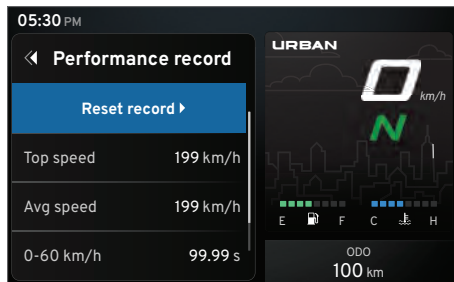

- Since this data is resettable, you can reset it if you wish to.
 - Select the 'Reset' option at the top of the window and press the 'ENT' button.
 - On pressing the 'ENT' button, a window gets popped up requesting your confirmation to reset.

f3. Documents

Using the 'Documents' option you can view the documents like Driving license, RC book, Insurance certificate copy stored in the TFT instrument cluster. These documents can be stored using TVS connect app. either from Android or from the iOS mobile phone and will work only when the phone is connected over Wi-Fi (refer [page 112](#) for the storage procedure).

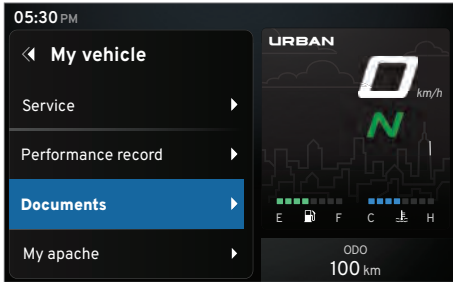

To view the documents:

- After entering the 'My vehicle' menu, select the 'Documents' option using 'Up' (e2) or 'Down' (e3) arrow ([ref. Fig. 24](#)).
- Once the 'Documents' option is selected, press the 'ENT' (e1) button.

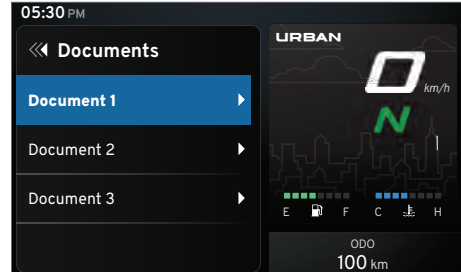

- The list of documents gets displayed.
- Navigate to the desired document list using 'Up' (e2) or 'Down' (e3) arrow and press the 'ENT' (e1) button to open the document.

Note

Total three documents only can be displayed in the TFT Instrument cluster. Document transfer will work only when VIN number in the TVS Connect App matches vehicle's VIN number.

Rider can be connected with the cluster over Wi-Fi when image transfer is in progress but 'Start Tour' functionality will not work when document transfer is in progress.

Note

Document transfer done through Wi-Fi.

Rate of document transfer may vary, based on type of mobile and software version. When ride is connected and document transfer is also ongoing, rate of document transfer may be reduced. While uploading documents, if the rider clicks 'UP' or 'DOWN' arrow, 'ENT' button for selecting other options, sometimes the cluster will not accept multiple inputs from the rider and it will remain same in uploading page.

If a document is partially transferred and subsequently deleted from the TVS Connect App, please ensure that it is also removed from the cluster before syncing a new document into the same slot.

f4. My Apache

- After entering the 'My vehicle' menu, select the 'My Apache' option using 'Up' (e2) or 'Down' (e3) arrow (**ref. Fig. 24**) and press the 'ENT' (e1) button to view the features of your TVS Apache RTX.

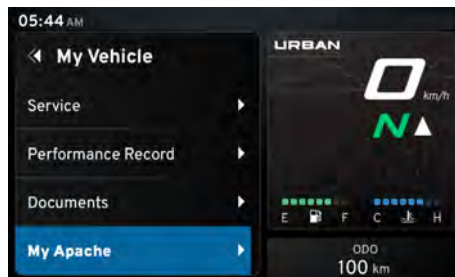

g) Display setup

- The display setup for the traction control, quick shift control etc. can be found under the 'vehicle Control' menu.

To enter the 'Display setup' menu:

- Keep the vehicle stationary and switch 'ON' the ignition. After the self-check, navigate to 'Display setup' in menu and press the 'ENT' (e1) button (ref. Fig. 24).

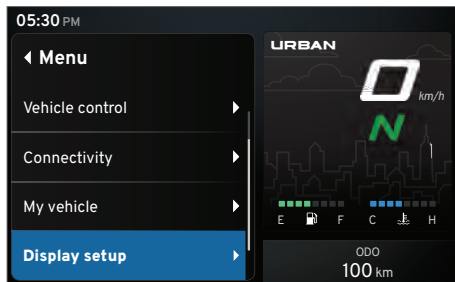

- The following are the control functions available under the 'Vehicle control' menu.

- g1. Custom widgets**
- g2. Display brightness**
- g3. Display theme**
- g4. High speed alert**
- g5. Clock setting**

g1. Custom widgets

In custom widgets (viz. ODO, Avg. Speed, Avg. Mileage etc.) can be used to display live feeds in the home screen of your connected TFT instrument cluster.

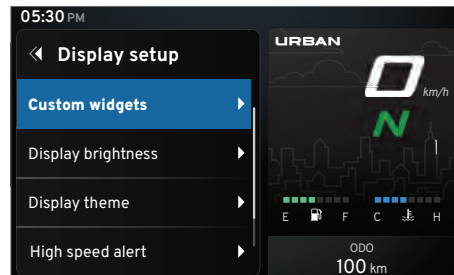

- After entering the 'Display setup' menu, select the 'Custom widgets' option using 'Up' (e2) or 'Down' (e3) arrow (ref. Fig. 24).
- Once the 'Custom widgets' option is selected, press the 'ENT' (e1) button.

- Inside the 'Custom widgets' option there are five custom widgets available for you to select and to customise. You can add different widgets to each custom widget and set required custom widget to your home screen as a default one.

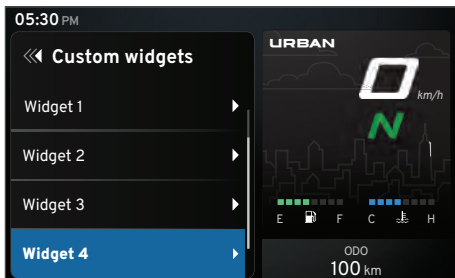

- In widget trip the below-mentioned four widgets are available in you can select any one.
 - ◆ Trip A
 - ◆ Trip B
 - ◆ Trip C
 - ◆ Day trip meter

Trip A, Trip B & Trip C meters

- Trip meter displays the trip distance travelled in kilometer since last reset.

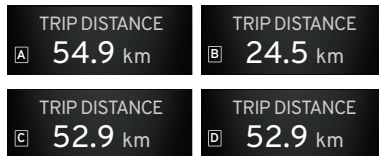

- Three trip meters (Trip A & B) with the range upto 9999.9 km is provided to measure different trips.
- The trip distance will be initialized to '0 km' automatically once reached 9999.9 km.
- User can reset the value.

Note

Trip details such as distance covered, time travelled, average speed, top speed, fuel consumed and average mileage are recorded by the trip details for individual journeys.

- In widgets 1,2,3 and 4 the below-mentioned nine specified widgets, you can select any four for displaying on the custom widget screen of main window:
 - ◆ Odometer
 - ◆ Trip distance
 - ◆ Avg. speed
 - ◆ Top speed
 - ◆ 0 - 60 km/h
 - ◆ Avg. fuel eco.
 - ◆ Range
 - ◆ Coolant temperature
 - ◆ Tyre pressure

Odometer

- (Odo meter) displays the total distance covered by the vehicle.



- The reading is saved permanently and cannot be reset under any circumstances.
- If the travelled distance exceeds 999999 km, the value '999999' will be displayed permanently.

Trip distance

- Trip distance displays the trip distance travelled in that particular trip.

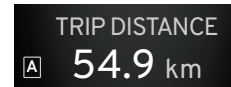

Average speed

- Displays the average speed of the vehicle based on total distance covered since last reset / by the total time when the engine rpm is greater than 500 rpm.

AVG. SPEED

57 km/h

Top speed

- Displays the top speed achieved by any user so far.

TOP SPEED

97 km/h

- If the vehicle's current speed is greater than the recorded speed, the new value will get updated automatically.
- User can reset and record a new speed data if required.

0-60 km/h

- This function lets you to measure the time to reach 0 to 60 km/h speed from rest and to view the best time taken so far.

0-60 km/h(S)

9.9 s

- If the current time is lesser than the stored value, the new value will get updated automatically.
- User can reset the value.

Avg. fuel eco.

- fuel economy Indicates the vehicle's mileage of the vehicle at that particular driving condition.

AVG. FUEL ECO.

27 km/h

- This value gets updated only after the vehicle speed increases more 10 km/h for the first time after ignition 'ON' and continue to update till the engine is switched 'OFF'.
- User can reset the value.

Range

- Indicates the approximate distance that can be covered by the vehicle with the available fuel in the tank.

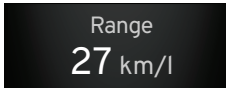

Note

Range will be shown as '--' for first 5 km and when the fuel bar is 1 bar and below after a battery reset. It will take around 100km to stabilize the range calculation.

Coolant temperature

- Coolant temperature indicator indicates the engine temperature in degree Celsius.
-

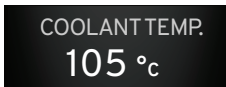

- Take the vehicle to the TVS Motor Company Authorised Premium Bike Dealers for further diagnosis if this indicator starts flashing.

- Similarly, if the coolant temperature indicator shows more than eight bars as shown below, take the vehicle to the TVS Motor Company Authorised Premium Bike Dealers for further diagnosis.



Caution

In case of coolant temperature sensor fault or cooling fan fault or throttle position sensor fault, the vehicle will go to reduced performance mode (limp-home) in order to safe guard the bike from any damage and also to protect the rider.

Tyre pressure**

- Indicates the tyre pressure of both front and rear wheel of the vehicle.

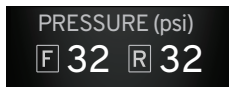

- There are two warning levels that will be displayed based on the pressure levels of the tyres. They are:
 - If the tyre pressure is low (25 PSI) the notification 'HIGH/LOW' tyre pressure will be displayed and the pressure values of widget changes from green to red colour.
 - If the tyre pressure is very high (39 PSI) the notification 'VERY LOW/VERY HIGH' tyre pressure will be displayed and the pressure values of widget starts blinking in red colour.

Note

Tyre pressure monitoring sensor (TPMS) is fitted in the tyres to measure and indicate the tyre pressure value. If the TPMS is replaced by any chance, it should be configured to the instrument cluster of your vehicle to get the tyre pressure indication. Contact any of our Authorised Premium Bike Dealers for doing the needful.

± 2 PSI difference is acceptable depending upon the altitude. There will be minor variations in tyre pressure when riding the vehicle on road as the tyre has the tendency to heat and cool down which may lead to pressure variations.

The values displayed in pressure gauge / gas stations may not match the values shown in the speedometer, due to the calibration differences in pressure gauges.

*** Applicable for specific variants only*

Pressure Zone	Tyre pressure (PSI)	Remarks
Normal pressure zone	26 to 38	No drop in performance
Low Air pressure zone	20 to 25	No drop in safety and slight drop in performance
Very low or critical air pressure zone	< 19	Noticeable drop in both safety and performance
High Air pressure zone	39 to 42	No drop in safety and slight drop in performance
Very high or critical air pressure zone	> 43	Noticeable drop in both safety and performance

g2. Display brightness

The 'Display brightness' setting allows you to adjust the brightness of your connected instrument TFT cluster.

- After entering the 'Display setup' menu, select the 'Display brightness' option using 'Up' (e2) or 'Down' (e3) arrow (**ref. Fig. 24**).
- Once the 'Display brightness' option is selected, press the 'ENT' (e1) button.

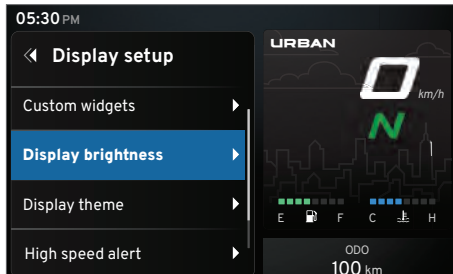

- There are two more additional modes available under the 'Display brightness' option and they are:
 - ◆ Auto adjust
 - ◆ Display brightness

- By setting display in 'Auto adjust', the connected instrument TFT cluster's intensity adjusts automatically based on the ambient light sensor.

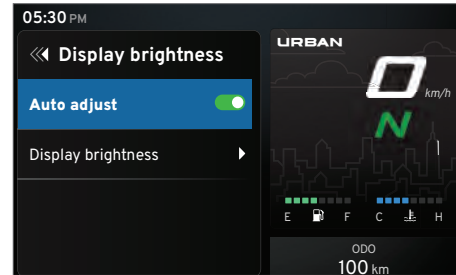

- When Display brightness mode is selected, the user can set to various levels based on your preference by using 'Up' (e2) or 'Down' (e3) arrow .

- Press the 'ENT' (e1) button after choosing the desired brightness level.
- Press the 'Return' button (e4) to come back.

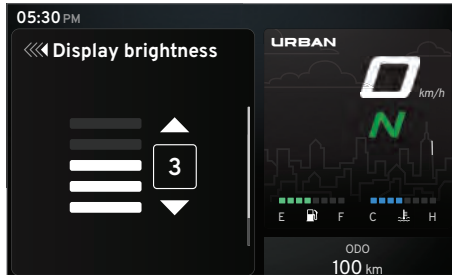

Note

The brightness ranges between 1 to 5 and can be set as per your preference.

g3. Display theme

The 'Display theme' feature allows you to set the display themes of your connected instrument TFT cluster.

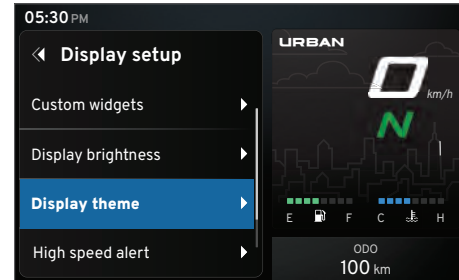

The 'Display theme' feature has the following three options and they are:

- ◆ Auto
- ◆ Light
- ◆ Dark
- After entering the 'Display setup' menu, select the 'Display theme' option using 'Up' (e2) or 'Down' (e3) arrow (ref. Fig. 24).
- Once the 'Display theme' option is selected, press the 'ENT' (e1) button.

- In auto mode, the connected TFT instrument cluster changes the 'Display theme' themes automatically with the help of photo sensor.

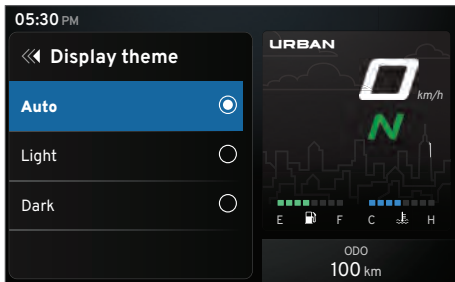

- When display theme is set as auto, display brightness will also be set as Auto.
- You also have the option to select between 'Light' or 'Dark' theme manually. Select the 'Light' or 'Dark' theme using 'Up' (e2) or 'Down' (e3) arrow and press the 'ENT' (e1) button to select.
- Press 'Return' (e4) button to exit.

g4. High speed alert

The 'High Speed alert' features allows you to set the speed alert of your vehicle.

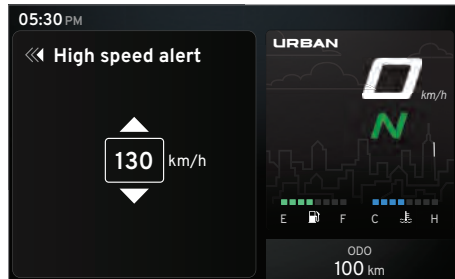

- After entering the 'Display setup' menu, select the 'High Speed alert' option using 'Up' (e2) or 'Down' (e3) arrow (ref. Fig. 24).
- Once the 'High Speed alert' option is selected, press the 'ENT' (e1) button.
- Press the 'Up' (e2) button to increase the speed alert and the 'Down' (e3) button to decrease the Speed alert.
- High speed alert warning is shown as soon as the speed exceeds the set limit.

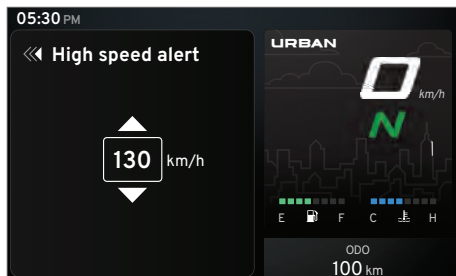

👁 Note

The default speed alert will be set as 80 km/h.

The over speed indication can be set between 40 to 130 km/h in intervals of 10 km/h. When speed remains more than set limit, High speed alert warning will be displayed.

g5. Clock setting

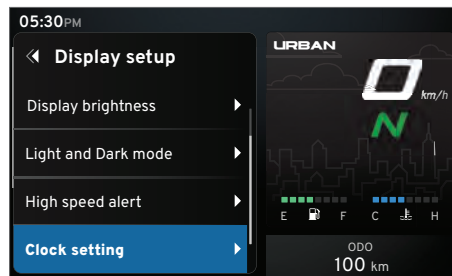

The 'Clock setting' features allows you to adjust the clock timing of your connected instrument TFT cluster. The 'Clock setting' feature has three settings and they are:

- ◆ Auto sync
- ◆ Time
- ◆ Format
- After entering the 'Display setup' menu, select the 'Clock setting' option using 'Up' (e2) or 'Down' (e3) arrow ([ref. Fig. 24](#)).
- Once the 'Clock setting' option is selected, press the 'ENT' (e1) button.

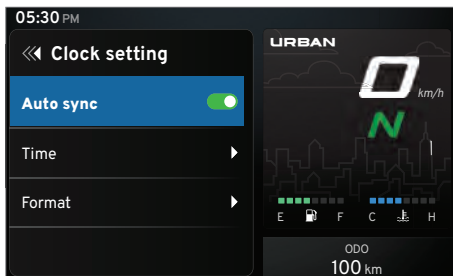

- In 'Auto sync' mode, the clock in the connected instrument TFT cluster will get auto-synced once the mobile is connected to the cluster. Refer [page 107](#) for detailed procedure of connecting the mobile.

Note

The clock time gets sync automatically on pairing your Android and iOS smart phone with the connected TFT instrument cluster provided if auto sync clock setting is enabled in app.

Auto Sync Not applicable for base variant

- Press the down (e3) button to select the 'Time' and press the 'ENT' (e1) button to select the following function.
 - In 'Time' mode, the hours value can be adjusted by using 'Up' (e2) and 'Down' (e3) button. Pressing the 'ENT' (e1) button sets the hour and the control moves automatically to minute value.

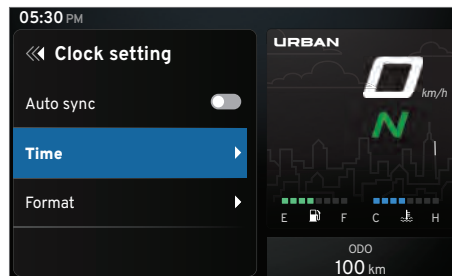

- Similarly, the minute value can be adjusted by using 'Up' (e2) and 'Down' (e3) button. Pressing the 'ENT' (e1) button sets the minute and the control moves automatically to 'AM' or 'PM' selection.

- Toggle between 'AM' or 'PM' using the 'Up' (e2) and 'Down' (e3) buttons and then press the 'ENT' (e1) button.
- Press 'Return' (e4) button to exit and set clock mode.
- Press the 'Down' (e3) button to select the 'Format setting' mode and press the 'ENT' (e1) button.
- The desired time format (12-hour or 24-hour) can be set by pressing the 'ENT' (e1) button while selecting any of the options.

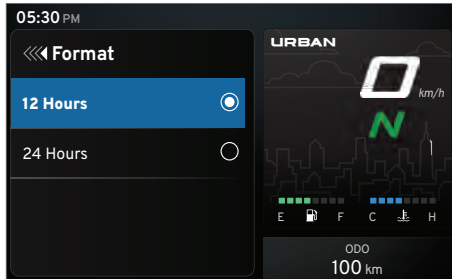

TVS Connect App



Dedicated smart phone app is available in the Google Play and the Apple store for your 'TVS Apache RTX' and it can be installed in your Android and Apple smart phones. To access the features of your TVS Apache RTX's connected TFT instrument cluster like :

- Incoming call alerts in connected instrument cluster.
- Missed call alerts in connected instrument cluster.
- Battery status, WiFi connection status and network status of your smartphone in connected instrument cluster.
- To send navigational assist instructions inputs to the connected instrument cluster from your smartphone.
- To save the last traveled route.
- To know the signal strength of your mobile network in connected instrument cluster.
- To generate and store Ride reports.
- To sync the connected instrument cluster clock with smartphone clock.

- To receive personalized message on special occasions (once's set on the app) on the connected instrument cluster.
- Map Mirroring functionality once enabled from navigation screen.

This dedicated mobile app of your TVS Apache RTX's can be downloaded from the Google Play and the AppStore® by searching the key word 'TVS CONNECT' else by scanning the below QR code.



Android

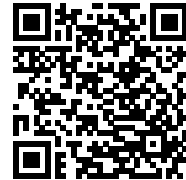

IOS

Note

This smart phone app is compatible with Android OS version 10 and above, iOS version 13 and above and the BLUETOOTH version 4.0 and above.

Android and Google Play are trademarks of Google LLC. App Store® and iOS are trademark of Apple.

If any issues with connectivity features please approach TVS Motor Company Authorised Main Dealer

Caution

While using the navigation feature, ensure you do not look at the speedometer for long as it might lead to an accident.

How to login

Upon launching the **TVS CONNECT** App for the first time, a scrollable introductory screen will appear.

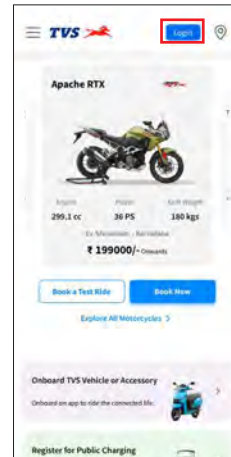

Click on the 'Login' tab provided at the top of the screen to begin a login process.

On entering the login screen, you will be prompted for your registered mobile number entry. Enter the mobile number and press 'Continue' tab to proceed further.



Now, an OTP verification screen will get open. Key-in or copy and paste the OTP received from TVSM to login.

Note

During login process, will be prompted for various permissions by the App. Provide necessary permission to the app to work seamlessly.

An logging in successfully the default vehicle screen opens as shown below with various informations.

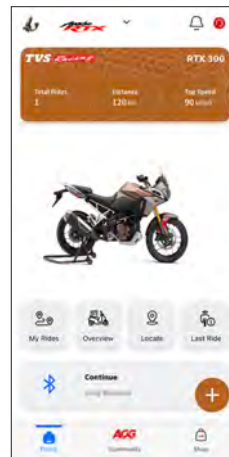

Onboarding TVS Vehicle

You can onboard your TVS vehicle into the App by following the procedure given below:

- Scroll down the initial screen and click on the 'Onboard TVS Vehicle or Accessory' tab and select the 'Onboard a TVS Vehicle' option.

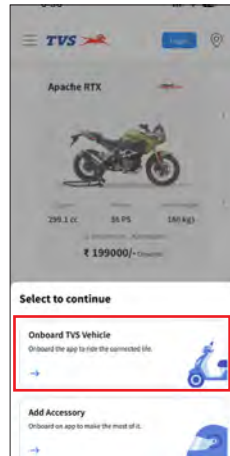
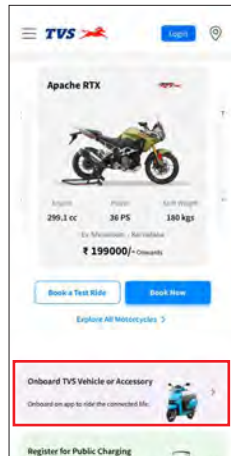

- On selecting this option, a screen with options of adding your vehicle or accessories will get open. Select the 'Add Vehicle by VIN' tab of the screen.
- Now, Another screen gets open with the VIN number and Invoice date or Engine/Motor number entering options.
- Key-in the necessary data to add the required vehicle and press the 'Add' button at the bottom of the screen.



Note

Please remember that the navigation license has to be renewed after 5 years of vehicle purchase and renewal can be done by contacting near by TVS Motor Company Authorised Main Dealer.

Refer App help for complete details.

First time Bluetooth pairing

To pair your Android smart phone or iPhone with your TVS RTX connected instrument cluster, via Bluetooth, for the first time.

- In order to pair device, select "Connectivity" option from 'menu' by navigating using 'Up' (e2) and 'Down' (e3) arrow (**ref. Fig. 24**).

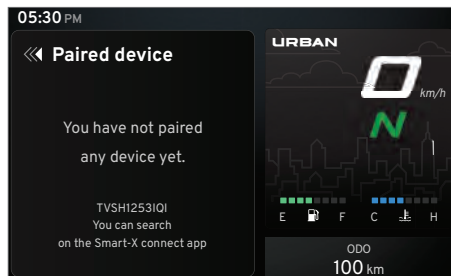

- Press the 'ENT' button again after selecting the required option.
- Press the 'Return' button (e4) to come out of menu selection window.
- While pairing new device the instrument cluster displays the above screen.

- Ensure that switch ON Bluetooth in your mobile device
- Open the **TVS Connect** app and press “CONNECT”; ensure the smart phone is near to the vehicle.



- Press and hold “CONNECT” for 2 sec to erase previous vehicle details and connect with a new vehicle in the TVS connect app.



- In connected TFT instrument cluster Bluetooth name is prefixed by TVS and followed by alphanumeric digits. Ex : 'TVS4B249484'.
- Now, select the 'TVS4B249484' in app to initiate the pairing process.



- Passkey will be display in the Connected TFT instrument cluster as shown.

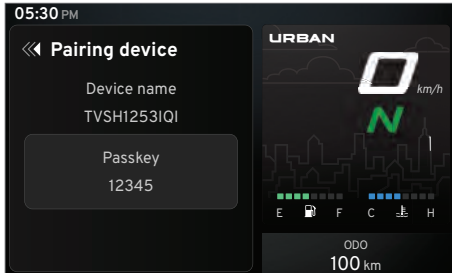

- Now, enter pass key '12345' in app to initiate the pairing process.



- On pairing, connected TFT instrument cluster displays 'CONNECTION SUCCESSFUL' message is display.

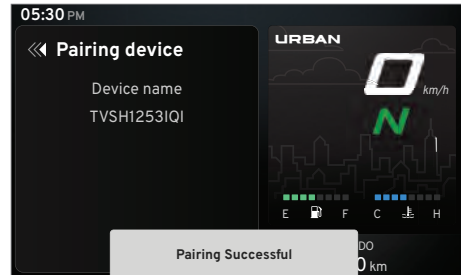

- Once device is paired, the Bluetooth '⌘' icon, Wi-fi '📶' icon once enabled, phone's battery '🔋' icon and signal strength '📶' icons will be displayed on the connected instrument cluster.



Note

During the course of pairing process, if there is any occurrence of error, the connected instrument cluster should be turned 'OFF' and 'ON', and the application also need to be restarted.

Please remember that, all the smart phones are not compatible for pairing with the TVS RTX's connected TFT instrument cluster.

During the search of Bluetooth devices in app, if the vehicle connected instrument cluster's Bluetooth device ID is not visible, try for one or two more iterations.

In your motorcycle only five devices can be added. To add a 6th device, delete any one paired device and try pairing a new device.

Only one iPhone can be auto-paired with a single instrument cluster at a time. If the user need to connect multiple iPhones with the single instrument cluster, the previous connected iPhone has to be forgotten by clicking, 'Forget This Device' from Bluetooth settings in the iPhone.

If the vehicle battery is reset or fuse is blown, then too 'Forget This Device' from Bluetooth settings in the iPhone has to be done.

Steps to "Forget This Device" in iPhone

If the user needs to connect multiple iPhones with the single instrument cluster, the previous iPhone has to be forgotten using "Forget This Device" from Bluetooth settings in the following manner:

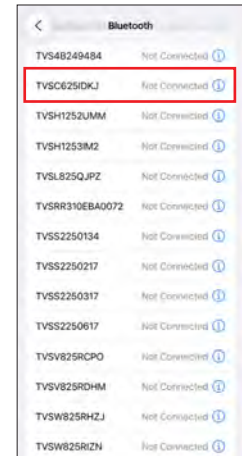
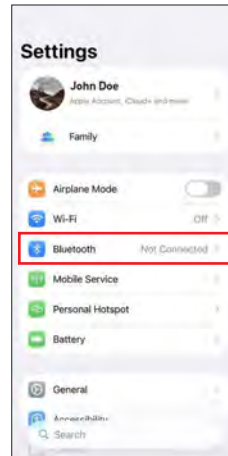

1. In the previous connected iPhone, open the SETTINGS -> BLUETOOTH.
2. Select the instrument cluster, which was connected previously.
3. Click on the "Forget this device"

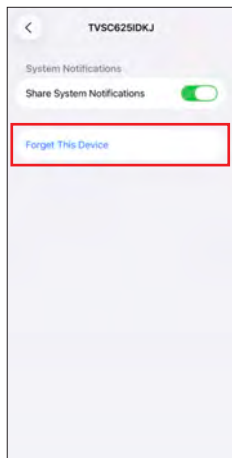

Steps to 'unpair' in android Phone

If the user needs to connect multiple android Phones with the single instrument cluster, the previous android Phone has to be forgotten using 'unpair' from Bluetooth settings in the following manner:

1. In the previous connected android Phone, open the SETTINGS -> BLUETOOTH.

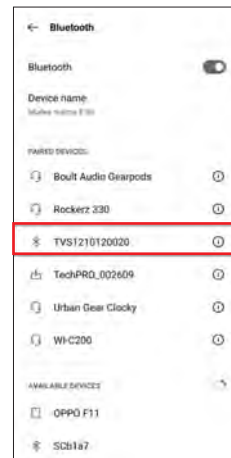
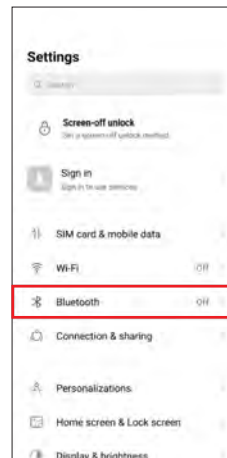

2. Select the instrument cluster, which was connected previously.
3. Click on the 'Unpair'.



Auto pairing

Once the first time pairing is done between vehicle's connected TFT instrument cluster and your smart phone, the phone will automatically pair with the vehicle when the following conditions are met :

1. Auto connect will happen after pairing only if app is opened in the mobile and connect button is pressed on the App.
2. If the ride is on going and the rider does ignition lock OFF and then ignition lock ON, then app gets auto connected and ride will continue on App until user ends the ride.
3. Once the rider ends the ride, to start a new ride he has to press connect button in the app.

Caution

In certain Android phones auto pair functionality does not work after first time pairing due to compatibility with various OS versions.

 **Note**

If the phone enters battery saver mode, auto-pairing might not happen. It takes maximum of five minutes for auto-pairing and it can happen in vehicle running or engine at idling or engine off condition.

Auto-pairing happens only if the application is locked in the RAM in multitasking screen of the phone with manufacture's customized OS (Ex : MI, Vivo etc.)

In case of Android phones with Android OS version 10 and above, for App to work seamlessly, any battery optimization setting to be removed in the TVS Connect App and GPS shall be allowed to run in background in high accuracy mode.

Even if your phone's Bluetooth is already paired to other gadgets like smart watch, health band or helmet, the auto-pairing works with your TVS Apache RTX's connected instrument cluster.

If the application unfortunately stops due to unforeseen circumstances, close and reopen the application and do the manual pairing for the first time, then auto pairing will happen subsequently.

 **Note**

Once the connected instrument cluster of your TVS Apache RTX is connected with your smart phone, the connected instrument cluster displays Bluetooth '⌘' icon, your mobiles battery level '🔋' icon and network providers signal strength '📶' icon.

In case multiple SIM cards are used in smart phone, by default, SIM 1's network provider's signal strength is shown in the display of connected instrument cluster.

Signal strength displayed in connected instrument cluster might vary from the display in smart phone as the former is referred from telephonic standards.

Once the cluster is connected with the smart phone, the cluster displays the signal strength of the network provider and the battery level of the smart phone. Number of unread messages and number of missed calls.



Incoming call alert display (📞🔊)

The connected instrument cluster will display the incoming calls from the smartphone via Bluetooth. Ex. 'Vishaagan' (along with profile image if available) will be displayed if the contact is stored in the smartphone otherwise number will be displayed.



👁️ Note

Incase multiple SIM cards are used in smart phone, by default, SIM 1's network provider's signal strength is shown in the display of connected instrument cluster.

Signal strength displayed in connected instrument cluster might vary from the display in smart phone as the former is referred from telephonic standards.

Missed call alert display '📞🔊'

The connected instrument cluster displays the missed call notification from the smart phone via Bluetooth on top right of the connected instrument cluster.

👁️ Note

*Incoming calls and missed calls can be cancelled by pressing the 'ENT button' on the handle bar (in IOS, **pressing the switch only clears the notification but the call will not be cancelled in the phone**).*

If DND option is enabled, the incoming call alert will not be displayed on the cluster. Also incoming caller image is supported only in Android mobiles.

Navigation window

Once the navigation assist is turned 'ON', the display of your TVS Apache RTX 300 motorcycle's connected instrument cluster enters into navigation window and displays the turn by turn navigation instruction with a simple and elegant graphical representation.



Note

In the event of an interruption or connectivity issue, the instrument cluster will display warning messages as illustrated below:



Low fuel alert

When the fuel level in the vehicle reaches the reserve level or empty level, a low fuel alert shall be displayed in the instrument cluster. The same alert will be also shown in the app.

LOW FUEL

Side stand alert

The side stand alert indicator turns 'ON' to alert you whenever the vehicle's side stand is deployed.

SIDE STAND DOWN

Note

In geared condition, if the side stand is deployed the vehicle will not start. In neutral condition, if the side stand is deployed the vehicle will start but as soon as the gear is engaged the vehicle will switch off.

If there is error in the side stand sensor the indication will blink and the vehicle will not start. In such a condition, please visit the nearest TVS Motor Company Authorised Main Dealer / Authorised Dealer.

Low battery alert

An low battery alert displays when the battery charge is too low. Following message also will be popped-up in instrument cluster the area when the low battery symbol is turned 'ON'.

LOW BATTERY

Get the battery checked at TVS Motor Company Authorised Main Dealer / Authorised Dealer.

Digi Docs

Digi Docs is used to transfer the images or documents such as driving license, RC book, Aadhar card etc. from the TVS Connect app to TFT Instrument cluster using both Android and iOS mobile phones. To enable Digi Docs transfer, the follow the steps given below:

- Open TVS Connect app.
- Click Digi Docs from side menu.
- You can see three options to store documents.

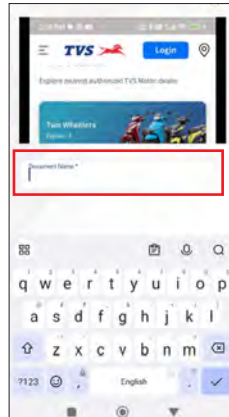
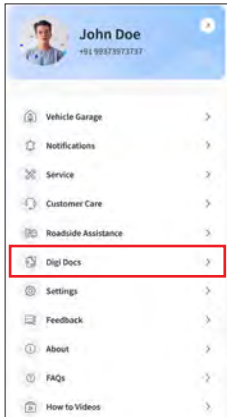

- Using the control switch you can navigate to Documents of the gallery (Refer [Page 36](#)).

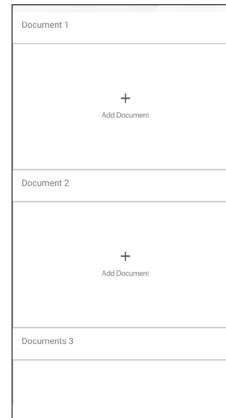

- Choose the desired image / document from the gallery and press save.
- Using 'ENT' (e1) button, 'Up' (e2) or 'Down' (e3) arrows and 'Return' (e4) button you can navigate through the documents ([ref. Fig. 24](#)).
- Once you selects correct document it will be shown on the cluster.

Note

Total of 3 documents can be stored in the TFT Instrument cluster.

Time to transfer one image without loss of data around 12 minutes.

Map mirroring

Map Mirroring functionality enables the instrument cluster to display navigation data from an Android or iOS device. This feature is integrated through the TVS Connect App, ensuring real-time map updates and route guidance.

To enable Map Mirroring the following steps needs to be followed:

- Ensure the TFT instrument cluster is connected with Bluetooth to TVS Connect App.
- Enable WiFi from the Live Dashboard and connect the phone with the cluster.
- Set destination on the navigation screen.

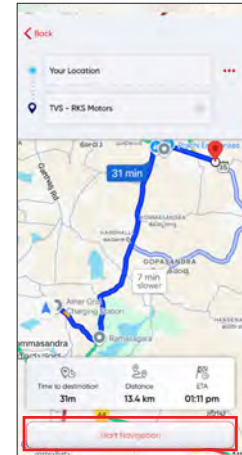
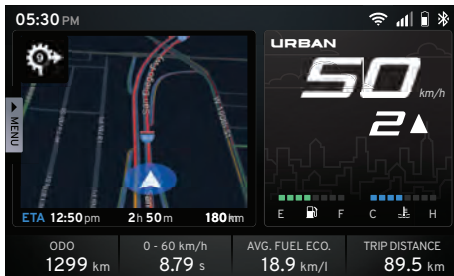

- App prompts to you if Google Map needs to be mirrored onto cluster. Press yes to confirm.
- You can now enjoy hands-free, distraction-free navigation throughout your journey.
- To go back simply slide the bar on the screen to exit mirroring.

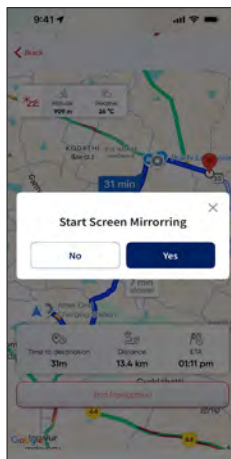

Note

If there is no mobile data or no network, Map will be on the same location until connectivity gets restored. Once resorted the location will move to the current location and navigation will function normally.

If the WiFi is not enabled then Map Mirroring will not work and only turn by turn navigation will be displayed. There will be a message on the cluster mentioning the same.

During an active call session or incoming call – Acceptance, Map Mirroring will automatically switch to turn by turn navigation and return to Mirroring state once the call has ended. This is normal.

Map mirroring will work only when the battery charge is above 20%. If the charge is below 20%, it will switch to turn by turn navigation.

Smartphones compatibility :

Android : Currently TVS connect App supports two versions behind the current Android OS.

iOS : The minimum support version of TVS connect App is two versions behind the current iOS release.

Music On Cluster

Music functionality enables the instrument cluster to display the current song being played from an Android or iOS device. This feature is integrated through the TVS Connect App. To enable Music functionality the following steps needs to be followed:



- Ensure the TFT instrument cluster is connected with TVS Connect App via Bluetooth.
- Select the music player from your phone.
- TFT instrument cluster displays the current song being played on selection of the music player.
- Control the songs being played by using the control switches. Refer [page 36](#) for details.

- You can now enjoy hands-free, distraction-free music throughout your journey.

Note

Currently, only Spotify is supported on Android along with Album art when available.

Note

This section shows the position and operation of the major components of your motorcycle.

Major Components (ref. Fig. 25)

- 1) Cooling system (radiator) (ref. [page 118](#))
- 2) Fuel tank cap (ref. [page 120](#))
- 3) Seat lock (ref. [page 123](#))
- 4) Adjustable rear shock absorber (ref. [page 137](#))
- 5) Coolant reservoir (ref. [page 118](#))

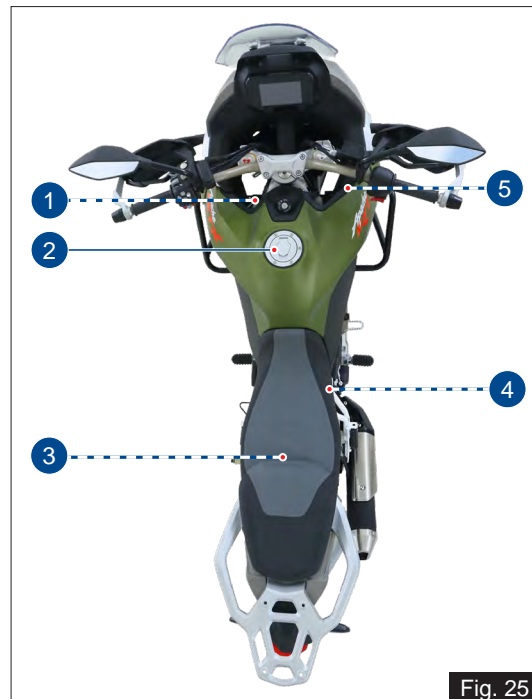

Fig. 25

* Hidden items are marked with dotted lines

DayTime Running Lamp (DRL) (Ref. Fig. 26)**

TVS Apache RTX comes with a day time running LED lamp which glows automatically once the ignition key is turned 'ON'.

After starting the engine / switching 'ON' the head lamp, the DRL continue to glow with reduced intensity of illumination (becomes Front Position Lamps)



*** Applicable for specific variants only*

LED Head Lamp (Ref. Fig. 27)

In case top variant

TVS Apache RTX comes with a LED head lamp which glows in 'low beam' once engine is in running condition and 'high beam' glows based on the beam control switch position if the engine is running condition.

In base variant

The 'low beam' glows once the ignition key is turned 'ON' and 'high beam' glows based on the beam control switch position.

The head lamp beam (high/low) can be controlled by pressing the beam control switch.



Cooling System (Radiator) (ref. Fig. 28)

A coolant is used in the motorcycle cools the hot engine and ensures that operating the vehicle at specified temperature which in-turn avoids the risk of malfunctions.

- A radiator and cooling fan fitted in the cooling system does job of cooling the coolant used in the motorcycle by air stream.
- Dirty cooling foils of radiator reduces the cooling effect. Do the visual check and ensure the cooling foils of the radiator are not clogged with any dirt or mud. If so contact TVS Motor Company Authorised Main Dealer.



Fig. 28

A coolant reservoir tank (A) is fitted on the right side of the motorcycle below the side panels (ref. Fig. 29).

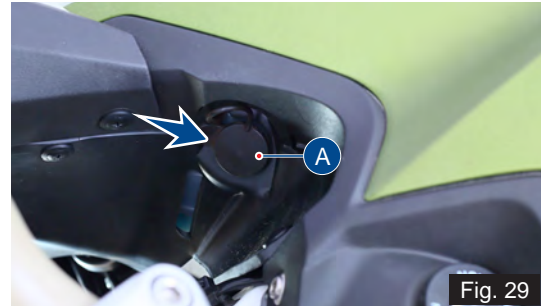

Fig. 29

Note

The cooling fan may switch 'ON' approx 22 secs. after the ignition is turned 'OFF' to reduce the heat and to protect the engine which is normal. Need not panic.

- Visually inspect the coolant level in the tank (use a torch if required).
- The coolant level should be between minimum and maximum level (1 & 2) on the tank (ref. Fig. 30).



Fig. 30

- Contact TVS Motor Company Authorised Main Dealer for topping-up if the level in the tank is lower than the minimum level.

Warning

Coolant is poisonous and health hazard. Avoid contact between coolant and body or clothing incase if you are handling it.

Caution

Use only recommended coolant (Glycentine G48, Coolant + Water; @ 50:50 ratio; total filling 1 litre). Use of improper coolant may cause damage, such as corrosion in the engine parts, blockage of the cooling passage or radiator and premature wear of the water pump seal.

Do not use tap water, or mineral water while topping-up the coolant.

Fuel Tank Cap (ref. Fig. 31)

This motorcycle is equipped with a lockable fuel tank cap (A).

To open:

- Lift the protection lid (B).
- Insert the control key into the lock. Rotate the key a 1/4 turn clockwise and lift the cap.



Fig. 31

To close:

- Push the cap down into its seat until hearing a click sound.
- Turn the key anticlockwise to the initial position and remove it.
- Close the protection lid.

Refueling (ref. Fig. 32)

- Never overfill the tank when refueling. The fuel level always be below the brim of the fuel tank neck (A).

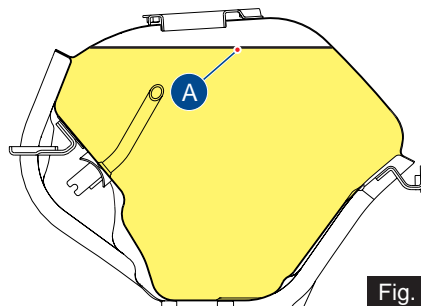

Fig. 32

** The fuel tank is not a measuring instrument and the capacity of the fuel tank may slightly vary from the indicated capacity.*

 **Warning**

Do not smoke while refueling. Do not use cell phones while refueling.

Avoid spilling of fuel on hot engine. Refill petrol in well ventilated area.

Switch 'OFF' the engine and ignition key while refueling as petrol is highly inflammable. Be sure there is no fuel trapped in the filler recess.

To avoid evaporation of petrol and deterioration of paint gloss due to ultra violet rays and heat of sunlight, always park your motorcycle in a covered parking.

Avoid using mobile phones for navigation while fueling.

 **Caution**

Check for abnormal jerk / noise while opening the cap / leak. If found any, contact TVS Motor Company Authorised Main Dealer.

 **Note**

After ignition 'ON', the instrument cluster checks for multiple parameters. Side stand status is one of such parameters. If the side stand is engaged, then the fuel level indication indicates the previously stored value. Once the side stand is dis-engaged, the fuel level display gets updated if there is any change in the volume.

Always make sure to close the cap properly after every refilling to avoid leak / evaporation.

It is always recommended to turn the ignition key 'ON' once the side stand is retracted.

Side Stand (ref. Fig. 33)

Side stand (A) can be operated with your foot. To support your motorcycle on side stand:

- Hold the motorcycle handle bars with both the hands and push down the stand with your foot until the stand is fully extended.
- Lean the motorcycle to the left until the stand contact the ground.
- To move back the side stand to its original position (horizontal position), tilt the motorcycle to the right and, at the same time, lift the stand with your foot.



Fig. 33

Caution

Before supporting the motorcycle on side stand, make sure that the supporting surface is hard and flat. Do not park the motorcycle on soft ground, gravel etc., else the bike may fall down.

While parking the motorcycle in downhill tracks, always park the bike in such a way that the rear wheel of the bike facing downhill.

Ensure not to disturb the side stand switch setting.

Warning

Do not sit on the motorcycle when it is supported on side stand.

Seat Lock (Rider and Pillion Seat)

This motorcycle is equipped with a removable rider and pillion seats. The seat lock (A) is located at the left side of the vehicle nearer to the rider seat as shown (ref. Fig. 34).



Fig. 34

To open pillion seat:

- Insert the control key into the seat lock. Rotate the key in clockwise until the lock is released (ref. Fig. 35).
- Once the lock is released, lift the seat front end and gently release it from the pillion handle hook at rear side and take out.



Fig. 35

To close pillion seat:

- Slide the rear end of the seat bottom underneath the pillion handle hook.
- Locate the seat lock pin into seat lock latch and gently press (at the front end).
 - Finally ensure that the seat is fastened securely to the frame along with the rider seat.

To open the rider seat:

- Remove the pillion seat as explained earlier.
- Gently lift the rider seat at the rear end and dislocate it from the fuel tank hook and take out (ref. Fig. 36).



Fig. 36

To close the rider seat:

- Slide the front end of the seat bottom underneath the fuel tank hook and align the seat properly as shown.
- Fix back the pillion seat and lock it securely along with the rider seat.

Caution

Since the rider and pillion seats are secured by a single latch, ensure that both seats are properly locked in place during reassembly.

The tool kit and first aid kit are located beneath the pillion seat and can be accessed by removing the pillion seat in case of an emergency (ref. Fig. 37).



Fig. 37

Caution

*Running-in is essential to preserve engine life and performance over time. Keeping to the running-in recommendations will ensure longer engine life and reduce the need for overhauls and re-tuning. Refer **page 08** for running-in information.*

Before Riding

- Ensure that tyre pressure is as per specification. Lower or higher tyre pressures are likely to cause instabilities in motorcycle behavior.



- Check operation of throttle, clutch, and brakes as well as free play on front and rear brakes. Pump in the brake lever and pedal a few times to ensure proper bleeding.



- Check both tyres for any wear or abnormalities. Ensure that wear is not below 'Tread wear indicator' mark.



- Check steering freeness, front and rear wheel freeness and alignment.



- Check tightening of wheel axle nuts, swing arm nut and steering nut.



- Also check tightening of front fork and shock absorber mounts.



- Check for chain slackness as per specification.



- Adjust mirror position to have optimum rear visibility. If you prefer track riding sans rear view mirrors, please remove and preserve them carefully.



Warning

Failure to carry out these checks before riding may result in damage to the motorcycle and injury to the rider.

- Check engine oil, brake oil and coolant oil levels.



While Riding

- Wear all necessary safety gears (Helmet, Jacket, Knee guards, Shoes and Gloves) before riding.





- Riding Posture - While riding, sit slightly behind the fuel tank. Body position should be relaxed such that back is very comfortable. Shoulders and arms should also be relaxed with slight bend in the arm as shown. Hold the handle bar with a good grip. Fuel tank should be firmly held by the thighs while riding. This will help maintain stability of the bike at all speeds.



- While riding, have a relaxed posture with wide vision.
- Ensure smooth operation of throttle, do not abruptly open the throttle especially in the corners
- Don't throttle while entering a turn. You may accelerate progressively while exiting a turn.
- Do not shift gears in a turn.

- Avoid abrupt hard braking, If hard braking is inevitable, release throttle and apply front and rear brakes in a progressive manner.
- Don't brake too hard while the vehicle is leaning, as vehicle may skid easily.
- Tyre grip reduces in cold conditions. It will take about 5 kms of riding for tyres to reach optimal temperatures.
- New tyres require running in for 20 kms before you can get the maximum grip.

Starting the Engine

- Turn-on the ignition key (ref. **page 27**). Ensure that the neutral indicator 'N' (I), ref. **page 47** is ON.
- Check that the engine cut-off switch is positioned at run mode '' and press the starter button '' (ref. **page 43**).

Warning

*Before starting the engine, familiarise your self with the controls which you need to use while riding (ref. **page 24**).*

Note

It is possible to start the vehicle with the side stand 'ON' and gear box in neutral. When starting the bike with the gear engaged, apply the clutch (the side stand must be up in this case).

If the battery voltage is too low, the system automatically disables the self-start function.

Caution

Do not rev the engine when it is cold. Allow some time for the oil to warm up and to reach all points that needs lubrication.

Moving the Vehicle

- Disengage the clutch by pressing the control lever.
- Press the gear shift pedal downwards with the tip of your foot to engage the first gear.
- Increase the engine speed by turning the throttle twist grip while gradually releasing the clutch lever; the motor cycle start moving forward.
- Release the clutch lever and increase the engine speed (increase the throttle).
- To up shift the gear, close the throttle to slow down the engine speed, disengage the clutch, lift the gear shift pedal up and release the clutch lever.
 - To down shift the gear, proceed as follows: release the throttle twist grip, pull the clutch lever, increase the engine speed for a moment to allow the gears to synchronise, down shift the gear and release the clutch lever.
 - Use controls wisely and promptly: when riding uphill do not hesitate to down shift the gears as soon as the vehicle tends to slow down. This will avoid stressing the vehicle and the engine abnormally.



Caution

Avoid sudden acceleration, as this may lead to misfiring, improper engagement of transmission (snatching).

Do not pull the clutch lever longer than necessary after engaging the gear. Otherwise the friction plates in clutch may get overheat and wears out quickly.

Braking

- Slow down the speed in right time, shift down the gear to use the engine brake, then apply both the brakes.
- Pull the clutch lever before stopping the motorcycle to avoid sudden stoppage of engine.

Warning

Use both front and rear brake for effective braking.

When riding in the rain or on slippery surfaces, braking capacity is significantly reduced. Always use the brakes very gently and carefully when riding under these conditions.

When riding downhill, shift down to the lower gears to use engine as a brake.

Caution

Keeping the brake applied continuously causes the brake pads (friction materials) to overheat and reduces the braking effectiveness which is dangerous.

Stopping the motorcycle

- Reduce speed, close the throttle and down shift the gears. Bring the transmission to neutral position just before the vehicle stops.
- Apply the brakes and bring down the motorcycle to complete stop.
- Turn 'OFF' the ignition.

Parking

- Stop the motorcycle. Place it on the side stand on a flat firm surface (ref. **page 122**).
- Turn the steering all the way to 'left' or 'right' and lock as explained in **page 27**. Take out the control key from the ignition lock.
- If the vehicle is parked in a garage or other indoor area, make sure that there is a proper ventilation and the motorcycle is not nearer to a source of heat.

Note

*You may switch 'ON' the hazard lamps if the vehicle is parked in hazardous location. Refer **page 31** for hazard lamps function.*

Warning

The engine and the exhaust system might be very hot even after switching 'OFF' the engine. Care should be taken not to touch the exhaust system with any part of your body.

Park the vehicle in a place where the pedestrians or children are not likely to touch the hot surface. Do not park the vehicle near dry grass or any other flammable resources which might catch fire.

Using padlocks or other locks like brake disc locks, rear sprocket locks etc. to prevent the movement of the motorcycle is very dangerous and may affect the motorcycle operation and safety of the users.

Fuel Recommendation

Use only BSVI ES Gasoline.

BS VI petrol containing upto 20% of ethanol by volume can be used.

Higher ethanol content in petrol can lead to

- degrade plastic and rubber components of fuel system and vehicle parts
- cause corrosion damage to metal parts like fuel tank, etc.

- result in startability & driveability issues
- decrease fuel economy

Ethanol absorbs water very easily, resulting fuel separation. Extra care shall be taken to prevent moisture entry into fuel tank while filling ethanol blended petrol and water washing of vehicle.

Painted parts (viz. panels, covers) shall not come in contact with ethanol blended fuels.

Manufacturer is not responsible for any warranty issues that results from using ethanol blend in excess of 20% by volume in petrol.

In case of any abnormalities observed due to use of ethanol blended fuels, customers are advised to use a different fuel station / brand for standard E20 fuel or contact authorised service centres.

- Refer **page 120** for fuel filling procedure.

Caution

Never mix oil in the petrol. Always fill fuel from reputed and reliable fuel stations.

Note

Use fuel additives in petrol (as recommended by additive manufacturer) for low carbon deposition.

Checks and Tips for Better Fuel Economy

- Carry out the periodic maintenance checks as specified in this manual (ref. [page 144](#)).
 - Regular maintenance checks will save fuel while ensuring trouble-free, enjoyable and safe riding besides keeping the environment clean.
- A dirty defective spark plug leads to wastage of fuel due to incomplete combustion.
 - Replace the spark plug every 15000 km. Use recommended plug only.
- A dirty air cleaner element restricts airflow and reduces fuel economy.
 - Replace the air cleaner element every 7500 km.
- Increase in engine rpm during acceleration, without increase in road speed indicates the clutch slip. A slipping clutch causes high fuel consumption and engine overheating.
 - Adjust the clutch play as explained in [page 150](#) if the above malfunction is observed.
 - If the condition persists even after adjusting the clutch play contact TVS Motor Company Authorised Main Dealer.
- Dirty or less engine cum transmission oil increases the friction between various parts of the engine and reduces engine life, and increases the fuel economy.
 - Inspect the engine cum transmission oil level as explained in [page 148](#) and top-up if necessary.
 - Engine cum transmission oil should be replaced as per the maintenance schedule without fail.
 - Always use recommended engine oil only (ref. [page 193](#)).
- Low tyre pressure has adverse effects on the vehicle. The drag on the vehicle increases resulting in decreased fuel economy. Further more handling may be affected adversely.
 - Check tyre pressure regularly and inflate them to recommended pressure (ref. [page 155](#)).
 - Never use tyre which are worn-out beyond the permissible limit.
- Check and ensure the drive chain slackness. Excess slackness lead to higher fuel consumption (ref. [page 159](#)).

- Check and ensure the free movement of wheels by rotating them to avoid wastage of fuel.
- A racing start from rest at full throttle will waste fuel and damage the engine. It is also creates potentially hazard traffic situation.
- Fuel is wasted whenever the rider suddenly accelerate or apply brake.
- While waiting for someone or stopping in signals for long time, if the engine is kept running at idle speed, leads to unnecessary wastage of fuel.
- Anticipate corners and slopes as well as the traffic conditions. Unnecessary and frequent braking reduces the fuel economy.

Rear View Mirrors LH & RH (ref. Fig. 38)

Adjustable rear view mirrors (LH & RH) are provided with your bike. These mirrors can be adjusted to your convenience by following the procedure given below:



Fig. 38

- Tilt the mirror portion (A) till the clear vision is obtained (up or down).

Caution

Never try to adjust the mirror position by mirror portion (A) this could break the mirror.

Gear Shift Pedal Position - Adjustment (ref. Fig. 39)

The position of gear shift pedal (A) of TVS Apache RTX can be adjusted in relation to the foot rest to suit the rider's requirement.

To adjust the gear shift pedal position:

- Using an open end spanner, hold the gear shift pedal link rod (1) on the hexagonal surface area of the rod.
- Using another open end spanner completely loosen the lock nuts (2 & 3).
- Now, turn the gear shift pedal link rod (1) 'in' or 'out' until the desired pedal position is set.

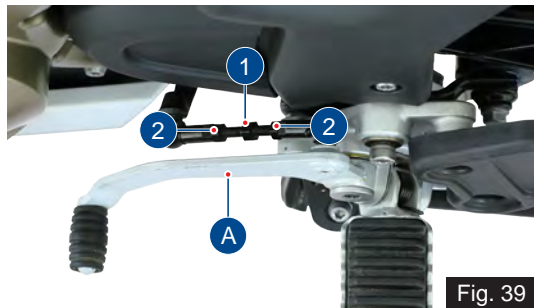

Fig. 39

- After obtaining the desired position, re-tighten the lock nuts (2 & 3) holding the link rod (1) in position.
- Ride the vehicle and ensure the gear shift is easy and convenient.

Note

Lock nut (2) has a left-hand thread and should be loosened or tightened in opposite direction.

Caution

Do not loosen the link rod to the maximum position (till the last thread). Else, it may come out from the shifting mechanism during ride.

Adjustment

Clutch Lever - Adjustment (ref. Fig. 40)

TVS Apache RTX comes with an adjustable clutch lever. There are four positions provided for you to adjust the lever to suit your palm size.

The lever can be adjusted by adjusting the position adjuster (A) provided in the lever itself. 'Position - 1' is the closest position of the lever to handle bar grip and 'Position - 4' is the farthest (**standard position of the clutch lever will be 2 & 3**).

To adjust the lever position, push the lever forward and rotate the position adjuster to any of the four positions by aligning the 'arrow mark' (B) on the lever to the number provided on the adjuster.

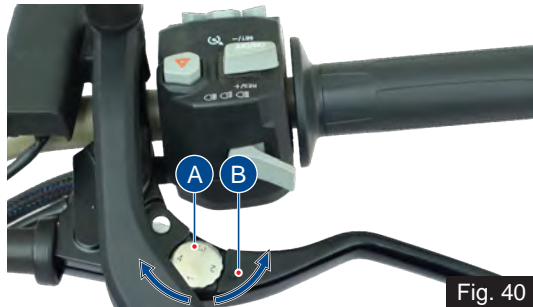

Fig. 40

Front Brake Lever - Adjustment (ref. Fig. 41)

TVS Apache RTX comes with an adjustable front brake lever. There are four positions provided for you to adjust the lever to suit your palm size.

The lever can be adjusted by adjusting the position adjuster (A) provided in the lever itself. 'Position - 1' is the closest position of the lever to handle bar grip and 'Position - 4' is the farthest (standard position of the front brake lever will be 2 & 3).

To adjust the lever position, push the lever forward and rotate the position adjuster to any of the four positions by aligning the 'arrow mark' (B) on the lever to the number provided on the adjuster.

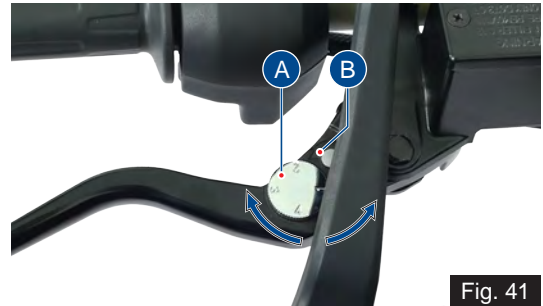

Fig. 41

Suspension

Front fork adjustment**

Compression damping force adjustment

The compression damping force adjustment is provided in the right leg. There are thirty clicks available for the compression damping force adjustment.

- To increase the compression damping force, turn the knob in clockwise and to reduce the compression damping force, turn the adjuster screw in anti-clockwise as shown in the figure (ref. Fig. 42).
- During the adjustment count the numbers of clicks from fully closed (clockwise) position.



Fig. 42

Rebound damping force adjustment

The rebound damping force adjustment is provided only in the left leg. There are thirty clicks available for the rebound damping force adjustment.

- To increase the rebound damping force, turn the knob in clockwise and to reduce the rebound damping force, turn the adjuster screw in anti-clockwise as shown in the figure (ref. Fig. 43).
- During adjustment count the numbers of clicks from fully closed (clockwise) position.



Fig. 43

Rear shock absorber's adjustment (ref. Fig. 44)

The pre-load of rear shock absorber can be adjusted as per rider's convenience and the load (weight of rider, passenger and luggage) on the vehicle.

There are 10 notches (1) for adjusting the pre-load of the shock absorber. Normally, the shock absorber's pre-load adjuster (2) will be positioned at 3rd notch (standard setting).

Increase the spring pre-load (shift to higher notches) for heavier rides.

Decrease the spring pre-load (shift to lower notches) for lighter rides.

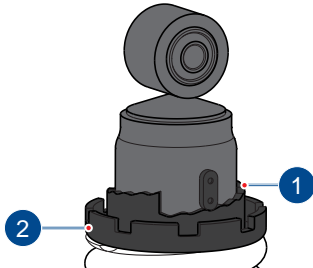

Fig. 44

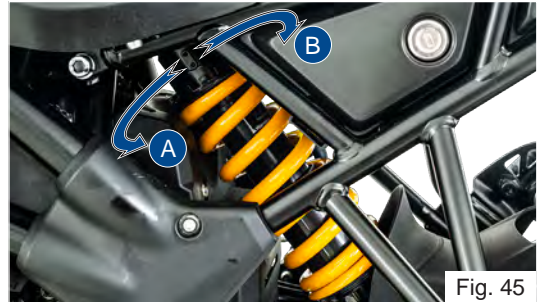

Fig. 45

To adjust the shock absorber's pre-load:

- Place the motorcycle on its stand on a firm and flat surface.
- Locate the adjuster shock absorber rear and handle ring spanner of tool kit (ref. [page 181](#)) properly into the notches of pre-load adjuster (ref. [Fig. 45](#)).
- Carefully rotate the adjuster clockwise (A) to increase the pre-load (hard suspension).
- Else, rotate the adjuster in anti-clockwise (B) to decrease the pre-load (soft suspension).

Warning

The rear shock absorber contains highly compressed gas. Do not try to open or disassemble it in any way.

Take a special care while turning the pre-load adjuster because, your hand may be striking against the other parts of the motorcycle if the adjuster spanner slips out of the pre-load adjuster notch.

Caution

Rear shock absorber to be adjusted only on the left side of the vehicle.

Adjust step by step (3rd to 4th notch and so on). Do not go at a stretch as it will damage the adjuster.

Rebound damping**

The shock absorber is provided with rebound damping force adjustment.

- To increase the damping, turn the adjuster knob clockwise towards H mark. And to reduce the damping, turn the adjuster knob in anti-clockwise towards S mark direction. There are twenty adjustment clicks available for the rebound damping force (**ref. Fig. 46**).
 - During adjustment count the numbers of clicks from fully closed (clockwise) position.

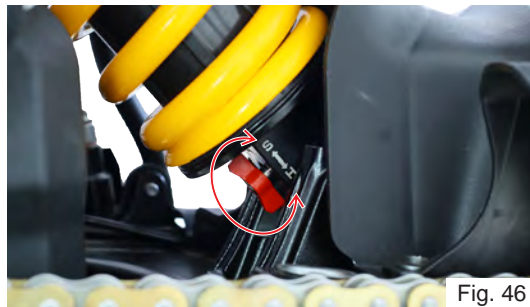

Fig. 46

** Applicable for specific variants only

Note

The motorcycle delivered with adjustable suspension shall be with standard setting. Refer suspension chart for various setting. However the mentioned suspension settings are only a guide setting requirements may vary for rider weight and personal preferences. For further information contact TVS Motor Company Authorised Premium Bike Dealers.

When adjusting the damping force setting, turn the adjuster screw in clockwise direction until it stops, noting that the first click counted as 1 then count the clicks turning in anti-clockwise direction. Although the damping adjuster may turn beyond the stated minimum settings, such turns are ineffective and advised not to turn further, as it may lead to the damage of damping mechanism.

Damping chart (Adjustable Suspension)

Vehicle payload condition	Front Fork		Rear Shock Absorber	
	Compression	Rebound	Rebound	Preload
Rider - standard	15	15	10	Standard (3 rd notch)
Rider and pillion	17	13	8	4 th notch
Rider and top box (5 kg)	17	13	8	Standard (3 rd notch)
Rider, top box (5 kg) and paniers (10 kg)	18	10	8	7 th notch
Rider, pillion and top box (5 kg)	17	13	8	5 th notch
Rider, pillion, top box (5 kg) and paniers (10 kg)	20	8	3	10 th notch
OFF road	18	13	8	Standard (3 rd notch)

Damping chart (Non - Adjustable Suspension)

Vehicle payload condition	Rear Shock Absorber Preload
Rider	Standard (3 rd notch)
Rider and pillion	5 th notch
Rider and top box (5 kg)	4 th notch
Rider, top box (5 kg) and paniers (10 kg)	5 th notch
Rider, pillion and top box (5 kg)	7 th notch
Rider, pillion, top box (5 kg) and paniers (10 kg)	10 th notch

Head Lamp Aiming

To check and adjust the head lamp focus:

- Inflate the tyres to the correct pressure.
- Place the motorcycle upright in a uniform flat surface while ensuring the headlamp center is 5 meter away from a vertical wall or screen (ref. Fig. 47)
- Mark a horizontal line on the wall or screen around 930 ± 20 mm from the ground level and mark a vertical line in the middle of the horizontal line (ref. Fig. 47)
- Sit on the vehicle to check the headlamp focus after completing the above procedure.
- Start the vehicle and turn the headlamp to 'high beam' mode.
- Rotate the handle bar left / right side and focus the headlamp on the vertical line of the wall / screen.

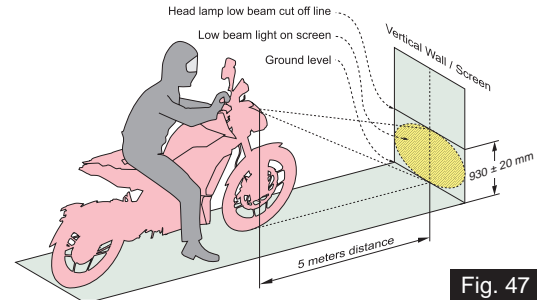

Fig. 47

- Now, turn the headlamp to low beam mode and ensure the headlamp low beam focus falls between 930 ± 20 mm from the ground level as shown (ref. Fig. 47).

Incase if any deviation is found, adjust the headlamp focus as explained below:

** The specification for head lamp beam adjustment is applicable only for India. Owner's of other countries are advised to adopt the local rules and regulations.*



Fig. 48

- Adjust the lamp adjuster clockwise (Downward) or in anti-clockwise (Upward) using the screw driver (ref. Fig. 48)
- Adjust the headlamp falls below the low beam cut-off line (800 ± 10 mm) marked on the vertical wall or screen.

Note

Head lamp aiming to be done with the unloaded vehicle only.

The adjustment levels mentioned is for solo riding condition. For dual riding condition, the head lamp beam may be adjusted as per need for better visibility.

Warning

Do not stare at LED head lamp beam to avoid damage to the eyes.

Maintenance Schedule

Maintenance schedule indicates the intervals between periodic services. At the end of each interval, be sure to inspect, check, replace, adjust, lubricate and service as instructed.

If the maintenance service is not done periodically, it will result in rapid wear and severe damage to the vehicle.

If the vehicle is used under high stress conditions such as continuous full throttle operation or rain, is operated in wet or dusty areas, certain jobs should be performed more often to ensure reliability of the vehicle.

Cylinder head, steering components, suspension, chain and wheel components etc. are key items and require very special and careful servicing.

We recommends that the jobs as per the maintenance schedule be performed by your TVS Motor Company Authorised Main Dealer.

Periodic inspections may reveal one or more parts that may need replacement. Whenever replacing any such parts we recommend to use only TVS Motor Company Genuine parts.

Perform pre-ride inspection (ref. **page 125**) before every scheduled maintenance.

I - Inspect	R - Replace	T - Top-up
C - Clean	A - Adjust	L - Lubricate
TI - Tighten		

Caution

*Proper running-in (ref. **page 08**) and maintenance is mandatory for making certain that your vehicle is reliable and gives optimum performance at all times. Make sure that the periodic maintenance is performed thoroughly in accordance with the instruction given in this User's manual.*

Use of non-genuine spares will affects the performance of the vehicle and failure to comply the warranty claims.

Check for any abnormal jerk during ride / any abnormal noise while opening the fuel tank cap / any leak in the fuel system. If found any, contact TVS Motor Company Authorised Main Dealer.

Periodic Maintenance Schedule (km or days whichever of the two occurs earlier)

List of operations and type of intervals		Free Service			After Free Service	
(km or days whichever of the two occurs earlier)	Service	1st	2nd	3rd	Every 7500 km or 6 months	Every 15000 km or 1 year
	Kms	750 - 1000	8250 - 8500	15750 - 16000		
	Period (days)	30 - 45	165 - 180	345 - 360		
Read out the faulty memory using diagnostics tool		-	I	I	I	-
Functioning of the electrical equipment's		-	I	I	I	-
Engine oil, oil filter along with drain bolt washer		R	R	R	R	-
Engine oil strainer		I & C	I & C	I & C	I & C	-
Air cleaner elements & air filter element box		-	R & C	R & C	R & C	-
Spark plug		-	-	R	-	R
Tappet clearance (adjust if required)		I & A	I	I	I & A	-
Clutch operation (adjust if required)		I & A	I & A	I & A	I & A	-
Coolant level, water hoses and O-rings (replace if required)		I	I	I	I	-
Radiator fan function / fins and deflector (clean if required)		I	I	I	I	-
Instrument cluster MIL lamp function		I	I	I	I	-
Gear shift lever mounting pin (lubricate using grease)		I & L	I & L	I & L	I & L	-

List of operations and type of intervals		Free Service			After Free Service	
(km or days whichever of the two occurs earlier)	Service	1st	2nd	3rd	Every 7500 km or 6 months	Every 15000 km or 1 year
	Kms	750 - 1000	8250 - 8500	15750 - 16000		
	Period (days)	30 - 45	165 - 180	345 - 360		
Front and rear brake discs		-				-
Front and rear brake pads		-				-
Tyre condition		-				-
Tyre air pressure		-	I & S	I & S	I & S	-
Front and rear brake system for damage and leakage		-				-
Brake fluid level of front & rear brake**		-	I & T	I & T	I & T	-
Rear mono-shock (clean if required)		I & C	I & C	I & C	I & C	-
Bust boots of the fork legs		-			C	-
Drive chain, rear sprocket and engine sprocket		I, A & L	I, A & L	I, A & L	I, A & L	-
Check the control cables for damage & routing without sharp bends						-
Steering head bearing play (adjust if required)		-	I & A	I & A	I & A	-
Headlamp low beam & high beam (adjust if required)						-

** Replace every one year

List of operations and type of intervals		Free Service			After Free Service	
		1st	2nd	3rd	Every 7500 km or 6 months	Every 15000 km or 1 year
(km or days whichever of the two occurs earlier)	Service					
	Kms	750 - 1000	8250 - 8500	15750 - 16000		
	Period (days)	30 - 45	165 - 180	345 - 360		
Fuel filter		-	-	R	-	R
EVAP drain pipe		C & DR	C & DR	C & DR	C & DR	-
Next service reset		RE	RE	RE	RE	RE

I - Inspect; R - Replace; C - Clean; A - Adjust; L - Lubricate; S - Set; T - Topup; DR - Drain; RE - Reset

Note

The service reminder will be displayed as a text warning - either 'SERVICE DUE' or 'SERVICE OVERDUE'. This reminder appears for 3 seconds during every ignition ON cycle after the self-check of instrument cluster and continues to appear until the service reminder is reset by an authorised TVS Motor Company Main Dealer. The 'SERVICE OVERDUE' warning specifically appears if the vehicle is not serviced after the scheduled service interval.

The 'Service Reminder' indicator activates 250 km or 15 days before the next scheduled service, based on the last service reset. For example, to remind you about the first service, the reminder will begin displaying from 750 km or 30 days, whichever comes earlier. This indication will remain active until the vehicle is serviced and the reminder is reset by an authorised TVS Motor Company Main Dealer.

If the vehicle is serviced before the scheduled due, the next service interval will be calculated based on the actual service kilometers or days at which the reset was performed. The service reminder will then appear accordingly, based on this updated schedule.

Safety Precautions

Before you are starting any maintenance repairs,

- Make sure that engine is in 'OFF' condition. This will help in eliminating several potential hazards like:
 - Poisoning from engine exhaust Carbon Monoxide (be sure there is proper ventilation whenever engine is operated in indoor).
 - Let the engine and exhaust to cool before working on the motorcycle to avoid burns from hot parts.
 - Do not run the engine without instruction for doing the same to avoid injury from moving parts.
- Carefully read the instruction before starting, and ensure that you have tools and skill required for doing the maintenance service.
- Park the vehicle on a flat firm surface with the side stand, center stand (if available) or the auxiliary stand (paddock stand refer [page 182](#)) to prevent the motorcycle from falling while doing the maintenance service.

- While working on batteries or fuel related items care must be taken to avoid fire or explosion. Use non-flammable solvent only. Keep away the fire (like cigarettes, sparks and flames etc.) from the battery and fuel related items.
- Ensure to remove the head lamp fuse, to avoid battery discharge during working.

Note

We recommend that the maintenance jobs as per the planned maintenance schedule be performed by your TVS Motor Company Authorised Main Dealer. Trained service personals of the Dealer can provide quality, reliable and economical service to your vehicle.

Use only TVS Motor Company Limited Genuine parts for long and reliable life of your motorcycle.

Engine Oil Level

Ensure the safety precautions listed in the [page 147](#) are followed properly.

Check the engine oil level before riding the motorcycle. Insufficient engine oil or too much engine oil affects the engine adversely.

- Wipe off the oil level inspection window located on the clutch cover near rear brake pedal ([ref. Fig. 49](#)).
- Start the engine and ride the vehicle for 5 to 6 minutes for oil to get warmed up sufficiently.
- Hold engine rpm 5000- 6000 for 30 secs and switch 'OFF' ignition. Hold the vehicle in upright condition with both the wheels on ground, on a flat and firm surface..
- After 2 to 3 minutes, inspect the oil level at the oil level inspection window and it should be between minimum level (1) and maximum level (2) mark as shown ([ref. Fig. 49](#)).
- If the level is below the minimum level (1), remove the oil filler plug (3) ([ref. Fig. 50](#)). Slowly add recommended engine oil till the level reaches to maximum level (2).

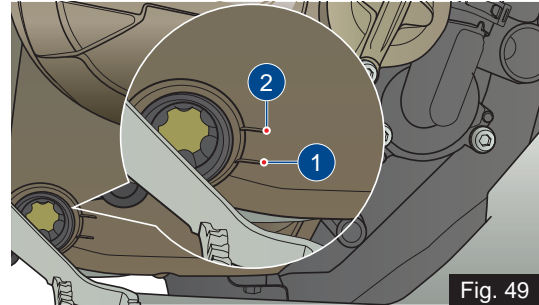

- Re-fix the oil filler plug after ensuring the correct oil level. Wipe out the oil traces with a clean cloth to prevent dust accumulation.

 **Caution**

Running the engine with insufficient or excess engine oil may cause serious damage to the engine.

For topping-up, always use TVS Motor Company recommended engine oil only.

Hold the vehicle in upright condition with both wheels on ground, on a flat and firm surface while checking the oil level to avoid wrong indication.

Engine oil and oil filter must be replaced by a TVS Motor Company Authorised Main Dealer at the intervals specified in the planned maintenance schedule without fail. Failing which disqualifies for warranty.

 **Warning**

Correctly recycle or dispose the used engine oil in order to avoid environment pollution.

Clutch Free Play

Ensure the safety precautions listed in the [page 147](#) are followed properly.

Clutch free play adjustment may be required if the motorcycle gets 'OFF' while shifting from neutral to gear or tends to creep; or if the clutch slips (vehicle acceleration lags behind the engine rpm).

Minor clutch free play adjustment can be done by means of clutch cable adjuster at the clutch lever end.

- Measure the clutch free play (A) at the lever end as shown ([ref. Fig 51](#)).
 - If the measured free play is 'more' or 'less' than the standard limit given below:

Clutch lever free play	8 to 12 mm
------------------------	------------

- Pull back the dust cover (1) of clutch lever ([ref. Fig. 52](#)).
- Loosen the lock nut (2) and turn the adjuster (3) 'in' or 'out' till the specified play is obtained ([ref. Fig. 52](#)).
 - After the adjustment, once again check the free play and confirm.



Fig. 51

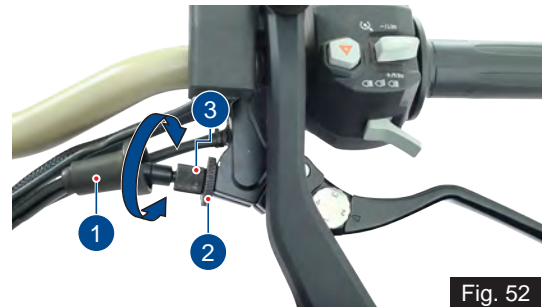

Fig. 52

- Lock the lock nut (2) again.
 - If the adjuster is threaded out to its maximum limit or if the correct free play cannot be obtained using the cable adjuster, loosen the lock nut and completely turn-in the clutch cable adjuster.
- Re-fix the dust cover (1).
- Loosen the lock nut (4) at the bottom end of the clutch cable (ref. Fig. 53).
- Turn the adjuster in (5) 'in' or 'out' until the specified play is obtained and then tighten the lock nut and check the adjustment once again (ref. Fig. 53).
 - After adjusting the clutch play, start the engine and engage the gear. Ensure that the engine is not stalling and not creeping.
 - Gradually release the clutch lever while slowly applying the throttle. The vehicle should begin to move slowly and accelerate smoothly. Else contact TVS Motor Company Authorised Main Dealer.

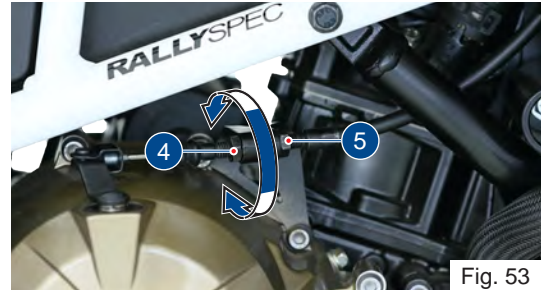

Fig. 53

⚠ Caution

Clutch play free play should be checked and adjusted only when the engine is cold.

During clutch play checking and adjustment, check the clutch cable for kinks or sign of wear that could cause stickiness or failure.

Lubricate the clutch cable using a cable lubricant available in the market to prevent premature failure and corrosion.

Brake Fluid Level

Brake fluid level should not fall below the MIN level mark on both front and rear brake fluid reservoir. If the level drops below the limit, air can get into the circuit and make the system ineffective.

Brake fluid must be topped up and changed at the intervals specified in planned maintenance schedule without fail for the proper working and to ensure the safety of the rider.

- Switch OFF and place the vehicle upright on a flat and firm surface using centre stand (if available) or on a auxiliary stand (paddock stand ref. [page 182](#)).



Fig. 54



Fig. 55

- Keep the handle bar straight.
- Inspect the oil level of both front and rear brake fluid reservoirs ([ref. Fig. 54 & Fig. 55](#)).
- If the level is lower than the MIN level mark in any of the reservoir, contact TVS Motor Company Authorised Main Dealer for topping up.
- If you find excessive play (sponginess) in the front brake lever or in the rear brake pedal, but both the brake pads are still in good condition, contact TVS Motor Company Authorised Main Dealer for the inspection of system and to do the air bleeding.

Note

Check the brake fluid level only when the handle bar and vehicle is in straight condition.

Warning

Lack of maintenance of the brake system increases the risk of accident. If you notice any malfunction in the brake system contact nearest TVS Motor Company Authorised Main Dealer for further diagnosis.

Caution

Inspect for any leakage of fluid in the brake circuit.

Cover the body parts with a protective cover before topping up the brake fluid to prevent the painted parts from getting damaged. In case of any fluid dripping on body panels, it is recommended to be cleaned immediately.

Use only BASF HYDRAULAN 404 / EQUIVALENT (DOT 4) brake fluid from a sealed container or drain the existing brake fluid completely from the circuit and use another brand (DOT 4) brake fluid to avoid mix up with existing old and different brand fluid.

Brake Pad Wear

- Visually inspect both front brake pads wear and rear brake pads wear.

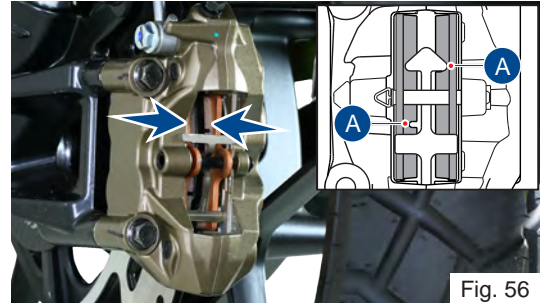

Fig. 56

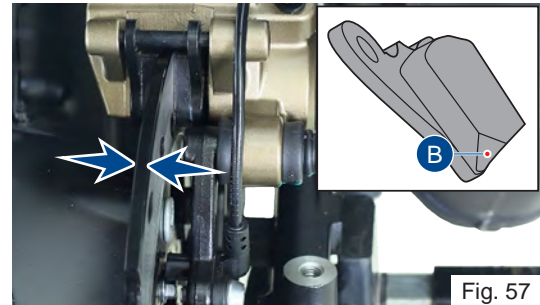

Fig. 57

- If the wear is found beyond the wear indicator (A & B) groove as shown in the figure in any one of the pad, replace brake pads as a set with a new one (ref. Fig. 56 & 57).

 **Warning**

If the brake pads are used beyond this groove, leads to metal support contact with the brake disc and affects the braking efficiency, disc integrity and leads to unsafe riding conditions to the rider.

 **Caution**

Replace the brake pads as a set, if the wear indicator shows beyond the wear limit.

Rims and Tubeless Tyres

Ensure the safety precautions listed in the [page 147](#) are followed properly.

Rims

- Visually inspect the front and rear wheel rims for any defects. If found any, have the rims inspected at TVS Motor Company Authorised Main Dealer and get it replaced if necessary.

Tyre pressure

Check the tyre pressures atleast once in a week if not more frequently. Insufficient tyre pressure not only fasten tyre wear, but also seriously affects the stability of the vehicle and may lead to rim bend or damage.

- Under-inflated tyres make smooth cornering difficult and over-inflated tyres decreases the contact with the ground which can lead to skidding and loss of control.
- As the tyre pressure is affected by changes in the temperature and altitude, check and adjust the pressure more frequently whenever your vehicle is used on such conditions.
- Be sure that the tyre pressures are within the specified limit at all times.

	On road (Solo / Dual)	OFF road
Front	2.25 kg/cm ² (32 PSI)	2 kg/cm ² (28 PSI)
Rear		

Warning

The tyre inflation pressure in cold condition is extremely important for the performance and the safety of the rider. Improper tyre pressure may result in: stability and handling issues, wobbling, hard steering, bumpy ride, uneven tyre wear etc.

When minor puncture occurs, tubeless tyres take a long time to deflate, as they tend to hold the air inside. If the tyres is found with low pressure, check the tyres for puncture.

Check and adjust the tyres pressure only when the tyres are cold.

Be sure to tighten the valve dust caps securely to prevent leaks while riding.

Ensure correct tyre pressure to avoid rim bend or damage.

Tyre tread condition

Whenever the tyre pressure is checked, ensure to check the tyre treads and side walls for wear, damage and foreign objects.

The tyres also to be checked for:

- Bumps or bulges in the sides of the tyre or in the tread.
- Cuts, splits or cracks in the tyre (replace the tyre without fail if found any of the above issues to ensure the safety of the rider).
- Replace the tyre when the tyre wears off to the tyre wear indicator level (1) which is indicated by the tyre wear indicator (TWI) mark (2) on the side surface of the tyre (ref. Fig. 58).



Fig. 58

- Tread depth of the tyre should be minimum 2 mm if the vehicle speed is higher than 100 km/h, and it shall be minimum 1 mm if the vehicle speed is lesser than 100 km/h.

Tread depth (min) :	2 mm (> 100 km/h)
	1 mm (< 100 km/h)

Warning

Visually inspect the tyres at regular intervals for cracks and cuts, especially on the side walls, and bulges or large stains that indicate internal damage. Replace them if damaged.

Remove any stones or other foreign bodies stuck in the tread.

Note

Tread wear marks are integrated into the main grooves on every tyre. If the tyre tread has worn down to the level of the marks, the tyre is completely worn. The location of the tread wear marks are indicated by an aero mark on the edge of the tyre (ref. Fig. 57). Replace the tyre when the minimum tread depth is reached.

Tyre replacement

- The tyres fitted on your motorcycle were designed to match the performance capabilities of your motorcycle and provide the best combination of handling, braking durability and comfort. The recommended tyres for your motorcycle are:

Front	EUROGRIP EXPLO - R PLUS 110/80 - 19 M/C 59H (tubeless)
Rear	EUROGRIP EXPLO - R PLUS 150/70 - R17 M/C 69H (tubeless)



- While re-assembling the tyre, ensure that the arrow mark (1) provided on the side walls of the tyre faces the direction of wheel rotation (**ref. Fig. 59**).

Warning

Have the tyres replaced at only TVS Motor Company Authorised Main Dealer or Michelin Authorised Dealer. Proper removal and reassembly of wheels and the tyres are essential.

Use only the recommended tyre. Use of a tyre other than the standard will cause instability. Be sure the wheel is balanced after the new tyre is installed.

Caution

Side walls of the tubeless tyres which are in contact with the wheel rim are only seals the air inside the wheel assembly. Hence, care should be taken not to damage the side walls of the wheel rim during removal and reassembly of the tyres.

 **Note**

Wheel balancing to be done every 1 year or every 10000 km. In addition, after every tyre puncture repair or replacement, wheel balancing to be done without fail. Do not remove or alter the position of wheel balancing weights after the completion of wheel balancing.

Tyre repair

- Do not repair the punctured tyre and it should be only replaced. If it is necessary to ride on a repaired tyre, never exceed the vehicle speed above 100 km/h until the tyre is replaced.

 **Warning**

Do not repair the punctured tyre. It should be replaced. If it is necessary to run the vehicle on a repaired tyre, never exceed 100 km/h speed until the tyre is replaced.

Never install a tube inside a tubeless tyre on this motorcycle. The tube may get burst during ride due to excessive heat buildup which will result in serious consequences.

 **Warning**

Since the rims of this motorcycle is designed for tubeless tyres, use tubeless tyres only. During hard acceleration or braking, a tube tyre could slip on the rim and deflate rapidly.

Drive Chain

Ensure the safety precautions listed in the [page 147](#) are followed properly.

The drive chain's service life is purely depended upon the proper lubrication and adjustment. Poor maintenance of drive chain can cause premature wear or damage to the drive chain and sprockets.

The drive chain must be inspected, cleaned, adjusted and lubricated as per the planned maintenance schedule. Under severe usage, or when the motorcycle is used more dusty or muddy areas, more frequent maintenance is necessary.



Fig. 60

Slackness inspection

- Ensure the engine is turned OFF and the vehicle is in neutral.
- Place the motorcycle on its centre stand (if available) or side stand or in auxiliary stand (paddock stand ref. [page 182](#)).
- Using the fingers, check the slackness of the chain at the lower portion, midway (A) between the sprockets (ref. [Fig. 60](#)).
- The slackness (A) should be between 20 to 25 mm at the various points of the chain.

Drive chain slackness	20 to 25 mm
-----------------------	-------------

- The chain should be adjusted at the point of least deflection.

Adjustment

- Place the vehicle on centre stand (if applicable) or side stand or auxiliary stand (paddock stand) on a flat firm surface.
- Remove the socket head mounting screws (1 & 2) and hexagonal screw (3) and remove the mudguard rear (ref. [Fig. 61](#)).



Fig. 61

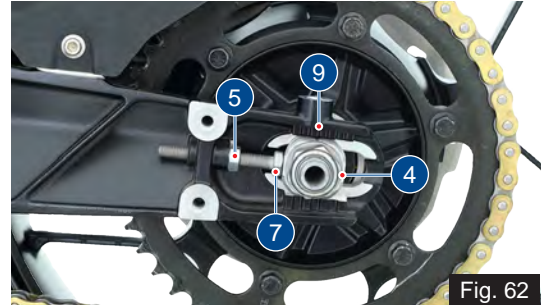

Fig. 62

- Loosen the rear axle nut (4) using a proper spanner from the tool kit (ref. Fig. 62).
- Release the lock nuts (5 & 6) (ref. Fig. 62 & 63) using proper spanner from the tool kit (ref. page 181).
- Turn the adjuster screws (7 & 8) 'in' or 'out' to obtain the specified slackness in the chain (ref. Fig. 62 & 63).
- While ensuring that the notch in the chain adjuster (9 & 10) is adjusted to the same scale value on both left and right sides, tighten the locknuts to the specified torque.

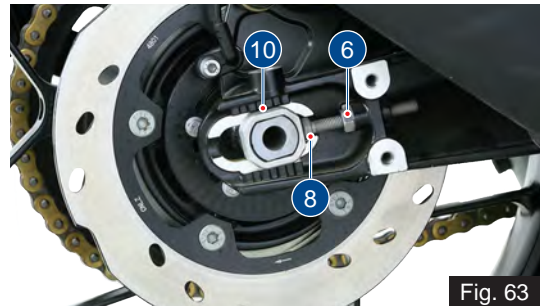

Fig. 63

- Similarly, tighten the rear axle nut and lock nut to the specified torque, and check and ensure the chain slackness (ref. Fig. 62 & 63).

Axle nut tightening torque	100 ± 15 Nm
Lock nut tightening torque	19 ± 3 Nm

⚠ Caution

Chain can be adjusted when vehicle is supported by centre stand (if applicable) or side stand or auxiliary stand (paddock stand) in no load condition.

Always have these tightening torques to be checked at TVS Motor Company Authorised Main Dealer after assembly for safety.

Cleaning

- Slowly rotate the rear wheel in driving direction or wheel rotation direction and spray the recommended cleaning spray.
- Leave the cleaning solvent to soak for few minutes. Wipe off the solvent on the chain with a dry, clean cloth thoroughly. Use a soft brush if the chain is dirty.

Lubrication

- Ensure the chain is cleaned thoroughly and the solvent is wiped off completely.
- Slowly rotate the rear wheel in driving direction or wheel rotation direction. Apply recommended spray liberally as shown to the drive chain inner lower runs (ref. Fig. 64).
- Ensure both the row links are lubricated.

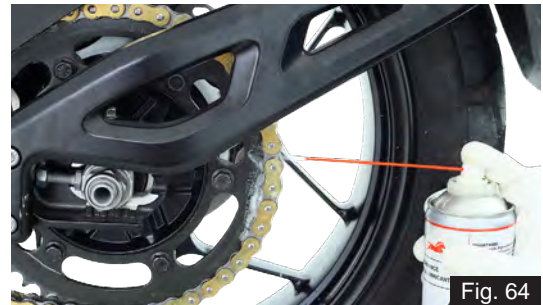

 **Warning**

Avoid getting lubricant on the brakes or tyres. Avoid applying excess chain lubricant to prevent spray onto your clothes and the motorcycle.

 **Caution**

The chain fitted on your motorcycle has X-Rings to protect the moving parts of chain from dirt, and to hold the lubricant inside. If the chain is cleaned using any solvent other than those specific for X-ring chains or washed using steam or water cleaners or a wire brush or an abrasive cleaner, the X-ring seals might be damaged irreparably.

Use only MOTUL C2 spray to lubricate the chain. Using non-specific lubricants may cause severe damage to the chain and the front and rear sprocket.

Front Wheel

Ensure the safety precautions listed in the [page 147](#) are followed properly.

Removal

- Carefully place the motorcycle in a stand supporting the vehicle with front wheel elevated.
- Loosen the left side clamping screws (1) and (2) ([ref. Fig. 65](#)).



Fig. 65

- Remove the locking screw (3) ([ref. Fig. 66](#)).
- Slightly press the quick-release axle (4) inward for a better grip on the right side.



Fig. 66

- Support the front wheel and slowly pull out the quick-release axle (4) from the left side. ([ref. Fig. 67](#)).



Fig. 67

- Place the front wheel down and roll it forward out of front suspension. Ensure not to damage the wheel speed sensor during the removal process.
- Take out the spacer bush (7) from the left side of the wheel hub (ref. Fig. 68).

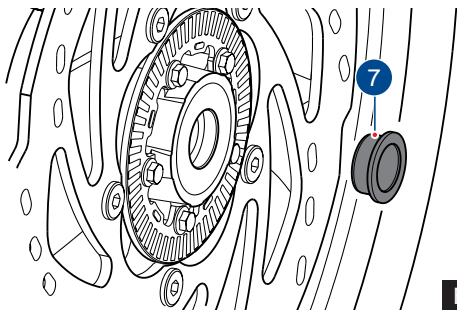

Fig. 68

Caution

Ensure not to damage the brake caliper during wheel removal.

Do not actuate the brake lever after the wheel is removed. Unintentional press of brake lever leads to brake pads binding.

Note

During the wheel removal, take additional care to prevent the wheel rims from scratches.

Reassembly

- Push the brake pads of front caliper away from together to ease the front wheel entry in to front suspension.
- Loosen the mounting screw (5) and take out the speed sensor (6) from front suspension.
- Fix the spacer bush (7) on the left side of wheel hub (ref. Fig. 68).
- With the care, roll the front wheel into the front suspension so that there is no damage to the wheel speed sensor.
- Lift the front wheel. While ensuring the proper seating of brake disc into the caliper assembly, insert the quick release axle.
- Remove the stand and stroke the front fork several times without applying the brake.
- Mount the front wheel stand again and install the locking screw (3) with specified torque (ref. Fig. 66).

Tightening torque	50 ± 7 Nm
-------------------	---------------

- Install the clamping screws (1 & 2) and tighten to the specified torque (**ref. Fig. 65 & 66**).

Tightening torque	19 ± 3 Nm
-------------------	---------------

- Assemble the speed sensor (5) and mounting screw (6) in front suspension.



Caution

Always have these tightening torques to be checked at TVS Motor Company Authorised Main Dealer after assembly for safety.

Rear Wheel

Ensure the safety precautions listed in the [page 147](#) are followed properly.

Removal

- Carefully place the motorcycle in auxiliary stand (paddock stand ref. [page 182](#)) or centre stand (if available).
- Place a support below the rear wheel to avoid falling of wheel after removing the quick release axle.
- Remove the mounting screw (1) from the speed sensor mounting and carefully take out the speed sensor (2) ([ref. Fig.69](#)).

- Remove the axle mounting nut (3) [ref. Fig 70](#) using the proper tool from the tool kit ([ref. page 181](#)).

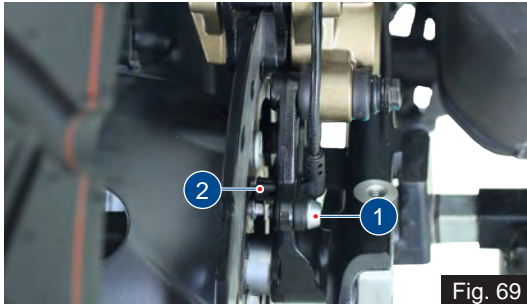

Fig. 69



Fig. 70

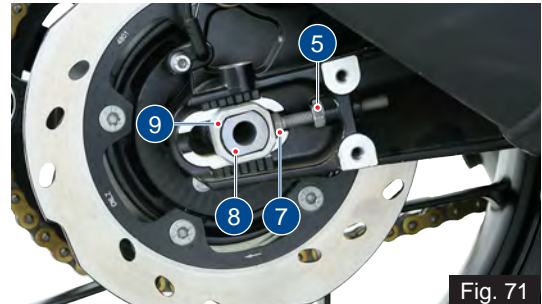

Fig. 71

- Release the lock nuts (4 & 5) and screw-in the adjuster bolts (6 & 7) (ref. Fig. 70 & 71).
- Push the quick-release axle (8) to the right as much as possible (ref. Fig. 71).
- Carefully pull out the quick release axle (8) from the left side and take out the chain tensioner (9) (ref. Fig. 71).
- Roll the rear wheel forward as far as possible and disengage the chain (10) from the sprocket (ref. Fig. 72).
- Care should be taken not to damage the wheel speed sensor during this process.

- Carefully roll the rear wheel out from the swing arm while pulling the brake-caliper assembly back far enough to allow the rear wheel to come out.

Caution

Care should be taken not to damage speed sensor during its removal and reassembly. Ensure that the speed sensor is free from any mud / clogging with dirt.

Ensure not to damage the brake caliper during wheel removal.

Do not actuate the brake pedal after the wheel is removed. Unintentional press of brake pedal leads to brake pads binding.

Note

Sprocket assembly, spacer axle LH & RH are loose fits in the wheel. Make sure that no parts are damaged or mislaid during removal and reassembly of the wheel.

During wheel removal, take additional care to prevent the wheel rims from scratches.



Fig. 72

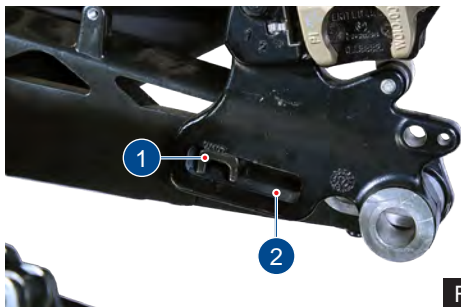

Fig. 73

Reassembly

- Carefully roll the rear wheel on the support into the swing arm, along with LH & RH spacers and sprocket, as far as necessary to allow the brake-caliper to be inserted while taking care of wheel speed sensor.
- Push the brake pads away from together to ease the rear wheel entry into swing arm.
- Place the brake-caliper (1) on the guide (2) of the swing arm as shown (ref. Fig. 73).
- Roll the rear wheel further into the swing arm, while pushing the brake-caliper assembly forward at the same time.

- Roll the rear wheel as far forward as possible and loop the chain over the sprocket.
- Insert the quick-release axle along with the chain tensioner from left side of the swing arm while ensuring that the axle is seated properly into all the components.
- Assemble the left side chain tensioner.
- Assemble the axle nut along with the washer and hand tighten it.
- Adjust the chain slackness and tighten the lock nuts, and the axle nut to the specified torque (ref. [page 202](#)).
- After tightening the axle nut, once again check and confirm the chain slackness.
- Assemble the speed sensor (2) and mounting screw (1) in rear caliper (ref. Fig. 69).

**Caution**

Chain can be adjusted when vehicle is supported by centre stand (if applicable) or side stand or auxiliary stand (paddock stand) in no load condition.

Always have these tightening torques to be checked at TVS Motor Company Authorised Main Dealer after assembly for safety.

Battery

Ensure the safety precautions listed in the [page 147](#) are followed properly.

Since the maintenance free battery is used in your motorcycle, it is not necessary to check the battery electrolyte level or add distilled water.

If your battery seems weak ie. if you are facing starting issues or other electrical issues, contact TVS Motor Company Authorised Main Dealer.

Removal

- Turn OFF the ignition.
- Remove the pillion and rider seats as explained in [page 123](#) to access battery.



Fig. 74

- Remove the mounting bolt and take the battery holder (A) ([ref. Fig. 74](#)).
- Disconnect the negative terminal (1) first followed by the positive terminal (2) ([ref. Fig. 75](#)). Carefully take out the battery.



Fig. 75

Re-fitment

- Reinstall the battery in the reverse order of removal.
- Connect the positive terminal first and then the negative firmly to avoid any damages to electrical system / battery. Make sure the rubber boot is intact with positive terminal.

 **Warning**

Battery develop explosive gases. Keep it away from heat sources. If charging is required, the battery must be charged in well ventilated area.

Unusable battery must be disposed in environment friendly manner. Do not discard it with household trash. Handover the battery to the battery Dealers or to a recycling centre that accepts used batteries.

 **Caution**

Never operate the motorcycle with discharged battery as it may damage electrical components.

Do not push start the vehicle, use a good battery or jump cable to start the vehicle incase of battery drain.

 **Note**

If the motorcycle is to remain unused for a long time (a month or longer), it is advisable to disconnect the battery terminals or have the battery removed by a skilled personnel.

Fuses

The electrical components of your motorcycle are protected by six fuses housed inside a fuse box and located below the rider seat.

To access the fuses, park the motorcycle on a flat and firm surface and remove the pillion and rider seats as explained in [page 123](#). A 'fuse puller' is placed on the battery holder can be used to pull out the fuse from the fuse box during replacement.

Removal and replacement

- Turn OFF the ignition.
- Press the lock and open the fuse box cover (1) ([ref. Fig. 76](#)).



Fig. 76

- Pull out the defective fuse and re-fix the new one with same rating.
- Close the fuse box cover and ensure the proper locking.

You can identify a blown fuse by the interrupted centre link (1) ([ref. Fig. 77](#)).

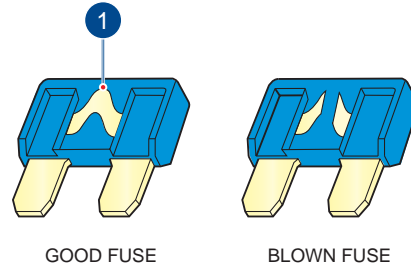

Fig. 77

Fuse assignments

- Each fuse inside the fuse box are assigned for different electrical load and it is listed the table given below. Never change the fuse rating to protect your electrical system and to avoid severe damages.

Fuse	Colour	Electrical load
F1 - 10A	Red	HECU
F2 - 10A	Red	EFI / USB (EMS) fuse
F3 - 15A	Blue	Load fuse
F4 - 15A	Blue	HECU
F5 - 30A	Green	Main fuse
F6 - 7.5A	Brown	Fan fuse
F7 - 10A	Red	EFI fuse
F8 - 7.5A	Brown	Headlamp fuse



Caution

Do not use the motorcycle by shorting the wires without a fuse. Never use a fuse with a rating other than that specified. Failure to observe above rules may damage the electric system or even cause fire.



Note

A sticker with fuse colour codes and rating is pasted inside the fuse box cover which can be referred during fuse replacement.

Care should be taken not to spray water on electrical components.

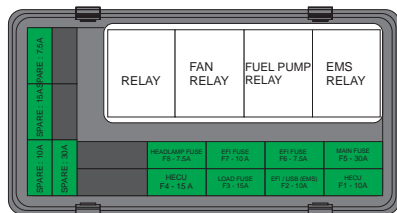

FUSE BOX

Fig. 78

Spare fuse location

- Spare fuse for the each of the fuse is located inside the fuse box (ref. Fig. 79).



Mirror Assembly

Ensure the safety precautions listed in the [page 147](#) are followed properly.

Assembly

- Assemble the adopter of the mirror assembly to the handle bar by rotating the adopter either in clockwise or in anti-clockwise based on the thread type ([ref. Fig. 80](#)).
- Release the lock nuts of the mirror assembly.

- Assemble the mirror assemblies to the adopter by rotating the mirrors either in clockwise or in anti-clockwise based on the thread type.
- Adjust the mirror to suitable position and tighten the lock nut using a open end spanner 14 mm from the tool kit (refer [page 181](#)).

Tightening torque	29 ± 6 Nm
-------------------	---------------



Fig. 80

Diagnostic Connector

The diagnostic connector is located below the rider seat. Follow the procedure given below to access the connector.

Removal

- Park the motorcycle on a flat and firm surface and remove the pillion and rider seats as explained in [page 123](#).
- Turn OFF the ignition.
- Gently pull out connector along with its cap from its location by releasing the lock (1) ([ref. Fig. 81](#)).
- Release the lock of the cap and take out the cap carefully.

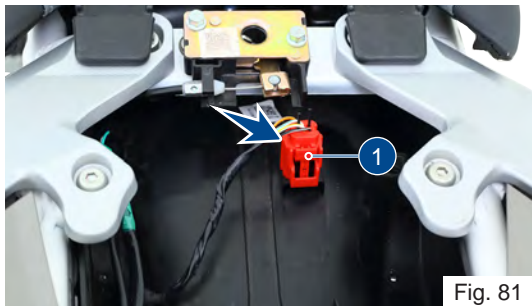

Fig. 81

Re-fixing

- Re-fix the cap of the connector and ensure the proper locking.
- Re-fix the connector to its location and lock it properly.

Caution

Diagnostic connector to be accessed and used by the trained personals of TVS Motor Company Authorised Main Dealer or by the other authorised persons of TVS Motor Company Limited during service. Do not fiddle with system at unauthorised service location.

Ensure to re-fix the diagnostic coupler cap after the usage to avoid damages to the electric system due to water entry. Secure the connector in it's location without fail to avoid getting damaged.

Cleaning your Motorcycle

For maintaining the original shine on metal parts surface and painted parts surface, wash and clean your motorcycle at regular intervals depending on usage and particular road conditions.

- Use only specific products. Avoid aggressive detergents and solvents.
- Use only water and natural soap to clean glass and the seat.
- To prevent stains, do not wash the vehicle immediately after it has been exposed to strong sunlight and do not wash it in the sun.
- If the parts of the engine are unusually dirty or greasy, use a de-greasing agent while taking care of transmission components (like chain, front and rear sprockets, etc.).



Caution

Never clean the motorcycle using hot or high pressure water jets. Cleaning the motorcycle with high pressure water jet may lead to serious problems in front fork, wheel assemblies, brakes, electrical systems, inlet and exhaust systems which will result in reduced safety.

- Transmission components can be rinsed with warm water and dried with clean dry cloth.
- Clean the radiator regularly. Use a hose with low water pressure to clean the radiator fins blockage. This prevents the engine from overheating due to insufficient cooling. Care should be taken not to damage the radiator fins during cleaning.



Warning

There may be a loss of braking efficiency immediately after washing the motorcycle. Greasing or lubricating the brake discs leads to loss of braking. Oil-free solvent to be used for cleaning the brake discs.

The head lamp may get fogged up after washing, rain or moisture. Switch ON the head lamp for a short period of time to dry any condensation.

Maintain minimum distance of 60cm between the water jet nozzle and the vehicle. Do not direct the jet onto electrical component and connectors.

Storage Procedures

For storing your motorcycle for longer periods of over a month and above, we recommend to carry out the following steps:

- Clean the motorcycle. Park the vehicle on centre stand (if applicable) or in auxiliary stand (refer [page 182](#)).
- Warm-up the engine and drain the engine oil.
- Empty the fuel tank.
- Remove the spark plug and feed in several drop of engine oil through the spark plug hole. Crank the engine few times and reinstall the spark plug.
- Disconnect and remove the battery. Store it away from direct sunlight and freezing temperatures. Place a suitable support at the bottom of the frame so that both the tyres are off the ground. This will ensure the better tyre life.
- Protect the vehicle with the suitable cover and store the vehicle inside a garage or similar area to avoid damage due to dust and rain.
- Make sure that the storage area is well ventilated and free from any source of flame or spark.



Caution

Do not park the vehicle on a slope or soft ground or else it may fall.

During storage the battery must be checked and if required recharged atleast once in a month.

Restoring the Motorcycle to use

- Take the motorcycle out of garage and clean the motorcycle thoroughly (ref. **page 177**).
- Remount the battery after bench charging if required.
- Fill the engine oil and check the oil level using the gauge.
- Lubricate the necessary parts.
- Fill up fresh fuel in the fuel tank (ref. **page 120**).
- Check and inflate the tyre pressure to the specified limit.
- Check and correct the points mentioned in pre-ride check (ref. **page 125**).

Note

Turn on the ignition and start the engine. Allow the to run in idle mode for few minutes and ride out.

Taking Long Trips

When taking the motorcycle a long trip more than 500 km follow the instructions given below:

- A) Keep the following items for use incase of emergency
- Complete tool kit and first aid kit.
 - Recommended spark plug one number.
 - Clutch cable each one.
- B) Precautions to be taken for the journey:
- Ensure engine oil and brake fluid level are upto the mark.
 - Ensure the coolant level.
 - Adequate fuel in the tank.
- C) Check the motorcycle for the following:
- Tightness of all fasteners for the correct torque value.
 - Fitness of tyres and tyre pressure.
 - Working of all the lamps and horn.
 - Balancing of wheel.
 - Smooth functioning of all cable and their free plays.
 - Smoothness of steering operation.

- Slackness and lubrication of chain.
- Front and rear brake functioning and rear brake switch working.
- Front fork for any abnormality.
- Spark plug cleanliness and condition.
- Air filter element cleanliness.
- Lubrication of all necessary parts.
- Any other jobs as necessary.



Caution

*Long journey are to be taken only after the running-in (ref. **page 08**).*

Have your vehicle checked for the above mentioned items at TVS Motor Company Authorised Main Dealer.



Note

Ensure the first aid equipments are changed periodically based on the expiry.

Tool Kit

To assist you in performing certain aspects of periodic maintenance and emergency repairs, a tool kit is supplied along with the vehicle.

- The tool kit (ref. **Fig. 82**) is located below the pillion seat (ref. **page 123** for seat removal procedure).
- The tool kit consists of one number each of the following:
 1. Tool bag
 2. Double ended open jaw spanner 12x13
 3. Double ended open jaw spanner 10x16

4. Bit +/-
5. Grip driver
6. Adjuster shock absorber rear
7. Handle ring spanner
8. Hexagonal key 5 mm
9. Ring spanner

Note

It is recommended to use the tool kit incase of any emergency only. It is always advisable to take your vehicle to TVS Motor Company Authorised Main Dealer.



Fig. 82

Auxiliary Stand (Paddock Stand)

Rear wheel stand

Use the rear wheel stand (the rear wheel stand is an accessory and it is available with the TVS Motor Company Authorised Main Dealer).

- Ensure that the motorcycle is parked on a flat and firm surface.
- Loosen the clamping screws (1) of the stand adopters.
- Move away the adopters (2 & 3) in such way that the swing arm fits between them (ref. Fig. 83).
- Ensure that the axle is not covered.



Fig. 83

- Position the stand (ref. Fig. 84).
- Make sure that the vehicle is secured so that it cannot topple sideways.
- Push the stand down until the motorcycle is standing upright and the handle of auxiliary stand is resting on the floor properly.



Fig. 84

Caution

When raising the motorcycle, make sure that the vehicle is secured so that it cannot topple sideways.

TVS Motor Company Limited ('the Company') gives this warranty with respect to the TVS Apache RTX manufactured by the Company.

While the Company has taken every care to maintain quality in the manufacture of the TVS Apache RTX, the above said warranty is subject to other terms of warranty:

- | | |
|------------------------------|---|
| Standard Warranty - | During 24 months from the date of purchase or during the first 30,000 km of run* |
| Additional Warranty - | During 36 months from the completion of standard warranty or during the first 50,000 km of run**. |

Whichever is earlier, the parts of the vehicle covered under warranty which prove to the satisfaction of the Company to have a manufacturing defect will be repaired or replaced free of cost. In the event of a change in vehicle ownership, the remaining warranty period is effective for the new owner.

The Company's obligation under this warranty is limited to repairing or replacing, free of cost, those parts of the vehicle which upon examination by the Company may prove to the Company's satisfaction to have a manufacturing defect, and in such cases the Company's decision either to repair or replace the affected parts will be final. In the event of replacement of parts, the Company also reserves the right to use parts of the same brand as the affected parts or any other brand which is used by the Company in the course of manufacture. All parts replaced under this warranty will become the property of the Company and must be returned to the company.

Limitations of Warranty:

This warranty shall not apply to following condition:

1. Any natural wear and tear, including without limitation, aging.
2. Warranty claims on proprietary items such as tyres and batteries etc., should be referred by the user directly on the respective manufacturer, as per their warranty terms and the Company shall not be liable in any manner in respect to the same.
 - Battery warranty for "MF type (Maintenance Free)" is applicable for a period of 21 months from the date of charging or 18 months from the date of sale or 20,000 kms, whichever is earlier.
 - Battery warranty for "Lead Acid type" is applicable for a period of 15 months from date of charging or 12 months from date of sale or 10000 kms whichever is earlier.

3. Parts repaired or replaced under this warranty are warranted only throughout the remainder of the original warranty period.
4. The Company is not liable for any delay in servicing due to reasons beyond the control of the Company or any of its TVS Motor Company Authorised Main Dealers.
5. In any event, the Company is not liable for indirect, remote, incidental or consequential damages.
6. The Company may make any modification or improvement to vehicles in future production at any time without prior notice and without any obligation to install the same on vehicles previously dispatched for sale.
7. Any claim under this warranty will lie only when the customer:
 - takes his vehicle to an TVS Motor Company Authorised Main Dealers and reports the problem he / she felt in the vehicle to enable the TVS Motor Company Authorised Main Dealers to inspect the same and assess the cause for the reported problems.
8. This is the only warranty given by the Company for the TVS Apache RTX. No employee, Dealer or other person is authorised to extend or enlarge this warranty.

 **Warning**

Modifications to this vehicle not approved by the TVS Motor Company may cause loss of performance and render it unsafe for use and disqualifies for warranty coverage also.

 **Note**

This warranty is applicable only for the vehicles availing warranty service (periodic service) when it falls due at TVS Motor Company Authorised Main Dealer only.

Following Toll Free numbers can be contacted for battery related queries if any:

Incase of EXIDE battery, call :- 1800 103 5454

Incase of AMARON battery, call :- 1800 571 5858

Incase of TATA GREEN battery, call :- 1800 419 8888

Standard Warranty (24 months or first 30,000 km) - List of parts not covered under warranty*

ITEM	WHAT TO CHECK FOR
Engine	-
Normal Maintenance Operations	Engine tune-up, decarbonizing, fuel system cleaning, oil and coolant changes, head light focusing, fastener re-tightening, tuning of EFI system, clutch, brakes, greasing of steering system and pivot pins as well as other normal adjustments.
Wear and Tear Items	Chain, sprockets, clutch and brake linings, fasteners, shims, washers, oil seals, gaskets etc.
Electrical	Fuse, LEDs are only in head lamp, tail lamp, turn signal lamps
Service Maintenance Parts	Oil filter, spark plug, air filter, oil, coolant, clamps
Rubber, Rexine and Plastic Items	All hoses , pipes and plastic aesthetics
Proprietary Items	Battery and tyres (the warranty terms are subject to our agreement with proprietary OEM) (Battery warranty for "MF type (Maintenance Free)" is applicable for a period of 21 months from the date of charging or 18 months from the date of sale or 20,000 kms, whichever is earlier). (Battery warranty for "Lead Acid type" is applicable for a period of 15 months from date of charging or 12 months from date of sale or 10000 kms whichever is earlier).
Other Factors	Parts of the vehicle getting affected due to atmospheric effect / environmental factors (rusting, paint peel off etc.). However, depending on the vehicle usage condition, warranty would be accepted up to 2 years from the date of purchase.

Standard Warranty (24 months or first 30,000 km) - List of parts not covered under warranty*

ITEM	WHAT TO CHECK FOR
Other Factors	Parts of the vehicle which have been tampered with, altered, repaired or replaced by persons not authorised by the Company and which in the sole judgement of the Company affect the performance of the vehicle.
	Parts which are used in conjunction with parts not made or recommended by the Company.
	Parts suffering damage or resultant damage by accident, misuse, negligent treatment, use of bad quality lubricants or coolant or impure fuel or by omission to follow the guidance and instructions contained in this User's manual.
	Vehicles on which engine number or chassis number is deleted, defaced or altered. Vehicles on which any warranty service including scheduled pay service is not availed when it falls due (at TVS Motor Company Authorised Main Dealer).
	Vehicles used for racing or any competition or used otherwise than for ordinary personal transportation. Vehicles which have been taken out of India. Vehicles affected by natural calamities like flood, earthquake, tsunami, storm etc,.
	If the vehicle has been used for commercial purpose like taxi or used for rental or hiring or any other purpose other than regular personal transportation.

Additional Warranty (36 months or first 50,000 km) - List of parts not covered under warranty**

ITEM	WHAT TO CHECK FOR
Engine	Guide cam chain, tensioner cam chain, cam chain, valves (for carbon deposition alone), finger follower and Stem oil seal
Normal Maintenance Operations	Engine tune-up, decarbonizing, fuel system cleaning, oil and coolant changes, head light focusing, fastener re-tightening, tuning of EFI system, clutch, brakes, silencer (aesthetic failures), suspensions (leakage failures), greasing of steering system and pivot pins as well as other normal adjustments
Wear and Tear Items	Chain, sprockets, clutch and brake linings, control cables fasteners, shims, washers, oil seals, gaskets etc.
Electrical	Fuse, headlamp, tail lamp, TSL, control switches, instrument cluster, wheel speed sensor, ignition coil, injector, relays and horn.
Service Maintenance Parts	Oil filter, spark plug, air filter, oil, coolant, clamps
Rubber, Rexine and Plastic Items	All hoses , pipes and plastic aesthetics
Proprietary Items	<p>Battery and tyres (the warranty terms are subject to our agreement with proprietary OEM)</p> <p>(Battery warranty for “MF type (Maintenance Free)” is applicable for a period of 21 months from the date of charging or 18 months from the date of sale or 20,000 kms, whichever is earlier).</p> <p>(Battery warranty for “Lead Acid type” is applicable for a period of 15 months from date of charging or 12 months from date of sale or 10000 kms whichever is earlier).</p>

Additional Warranty (36 months or first 50,000 km) - List of parts not covered under warranty**

ITEM	WHAT TO CHECK FOR
Other Factors	Parts of the vehicle getting affected due to atmospheric effect / environmental factors (rusting, paint peel off etc.). However, depending on the vehicle usage condition, warranty would be accepted up to 2 years from the date of purchase.
	Parts of the vehicle which have been tampered with, altered, repaired or replaced by persons not authorised by the Company and which in the sole judgement of the Company affect the performance of the vehicle.
	Parts which are used in conjunction with parts not made or recommended by the Company.
	Parts suffering damage or resultant damage by accident, misuse, negligent treatment, use of bad quality lubricants or coolant or impure fuel or by omission to follow the guidance and instructions contained in this User's manual.
	Vehicles on which engine number or chassis number is deleted, defaced or altered. Vehicles on which any warranty service including scheduled pay service is not availed when it falls due (at TVS Motor Company Authorised Main Dealers).
	Vehicles used for racing or any competition or used otherwise than for ordinary personal transportation. Vehicles which have been taken out of India. Vehicles affected by natural calamities like flood, earthquake, tsunami, storm etc.,
	If the vehicle has been used for commercial purpose like taxi or used for rental or hiring or any other purpose other than regular personal transportation.

Service Information

Your TVS Apache RTX is covered by a planned service schedule comprising eleven services during the warranty period. Among these, the first three are free services, for which labour charges are free. In addition to this free services, there are eight pay services under our scheduled maintenance scheme.

A detailed service schedule sheet is provided in this manual for your reference and follow-up (ref. [page 191](#)).

These warranty services can be availed at scheduled intervals at any of the TVS Motor Company Authorised Main Dealers. Regular periodic maintenance is essential for ensuring optimal performance and longevity of your vehicle. Our services are planned to keep your TVS Apache RTX running at its best.

Please make sure your vehicle is serviced at the recommended intervals at any of our Authorised Main Dealers to maintain eligibility for warranty coverage.

Even after the completion of the scheduled services, we strongly recommend continuing periodic maintenance based on your vehicle's usage. This will help preserve its performance and reliability over time. If you require any clarification or assistance, feel free to write to us. Kindly include the frame number, engine number, date of purchase, and the name and location of the Authorised Main Dealer from whom you purchased and are servicing the vehicle.

Service Department

TVS MOTOR COMPANY LIMITED

P. O. Box No. 4, Harita, Hosur - 635109,

TAMILNADU, INDIA.

Toll free no. :- 1800-258-7111

Pre-Delivery Inspection

Sl. No.	Description
1	Inspect the vehicle for any visible damages / scratches
2	Inspect the battery charge and terminals connections
3	Ensure first aid kit and tool kit placed in the vehicle
4	Install left and right side mirrors
5	Inspect drive chain slackness and adjust if required
6	Inspect front and rear tyre pressure and inflate to specification if required.
7	Fill the fuel in the vehicle
8	Inspect the startability of the vehicle
9	Inspect and ascertain the working of all lamps and horn
10	Inspect head lamp focus and adjust if required
11	Conduct engine start suppression test
12	Test drive vehicle and ensure proper working of all controls and system
13	Clean the vehicle thoroughly
14	Using diagnostic tool, ensure there is no error codes
15	Code the service interval (distance and time) using diagnostic tool
16	Explain of the product features and operations to the customer
17	Check the front wheel and rear wheel freeness
18	Ensure any additional points communicated by TVS Motor Company Limited during the course

Planned Service Schedule (kms or days / months whichever of the two occurs early)*

Sl.No.	Service	Type	Kms	Days / Months
1	1st Service	Free	750 - 1000	30 - 45 days
2	2nd Service	Free	8250 - 8500	165 - 180 days
3	3rd Service	Free	15750 - 16000	345 - 360 days
4	4th Service	Pay	23250 - 23500	525 - 540 days (18 months)
5	5th Service	Pay	30750 - 31000	705 - 720 days (24 months)
6	6th Service	Pay	38250 - 38500	885 - 900 days (30 months)
7	7th Service	Pay	45750 - 46000	1065 - 1080 days (36 months)
8	8th Service	Pay	53250 - 53500	1245 - 1260 days (42 months)
9	9th Service	Pay	60750 - 61000	1425 - 1440 days (48 months)
10	10th Service	Pay	68250 - 68500	1605 - 1620 days (54 months)
11	11th Service	Pay	75750 - 76000	1785 - 1800 days (60 months)

Note

Free service entitles the customer to avail service as detailed in service instructions at free of labour charge. Cost of oil, coolant, brake fluid and other materials for the free service is chargeable. Charge for the pay services, cost of oil, coolant, brake fluid and other materials for the pay service should be borne by the customer.

* Please remember that, after the above schedule, periodic servicing of your vehicle at appropriate intervals, depending upon its extent of use, will keep your vehicle at its best level of performance.



Busy Life? Easy Servicing!

Now, service your bike anywhere, anytime.

- ★ Service the vehicle at your door step.
- ★ Available for regular maintenance or breakdown service only.
- ★ Offered at nominal convenience charges.

Contact your nearest Dealership for details.[†]

[†]Facility available at selected Dealerships only. Terms and conditions apply

Recommended Fuel and Lubricants

Fuel	
Recommended fuel grade	BSVI ES Gasoline (containing upto 20% of ethanol by volume)
Fuel capacity (usable)	12.6 ltr
Minimum required quantity of fuel	1.5 ltr
Engine Oil	
Recommended manufacturer	TVS
Recommended grade	TVS TRU4 Expedition (API SP 5W-40 JASO MA2)
Recommended quantity	1500 ml (fresh assembly) 1300 ml (full drain along with oil filter change)
Coolant	
Recommended manufacturer	Glysantine
Recommended grade	G48
Recommended quantity	1 litre (coolant and distilled water ratio 50:50)
Cone set grease	
Recommended manufacturer	As recommended by TVS Motor Company
Recommended grade	BEM 34-132
Recommended quantity	15 gm (in sachet)

Recommended Fuel and Lubricants

Front fork oil	
Recommended manufacturer	ENDURANCE
Recommended grade	ETL 1F
Recommended quantity	LH - 350 ml, RH - 350 ml
Chain cleaner	
Recommended manufacturer	MOTUL
Recommended grade	C1
Brake Fluid	
Recommended manufacturer	BASF HYDRAULAN 404 / EQUIVALENT
Recommended grade	DOT 4

Engine

Bore	78 mm
Stroke	62.6 mm
Displacement	299.1
Compression ratio	11.6 ± 0.3 : 1
No. of valves	4
Maximum power (Urban and Rain mode) (Tour and Rally mode)	21.5 kW @ 9500 rpm 26.5 kW @ 9000 rpm
Maximum torque (Urban and Rain mode) (Tour and Rally mode)	24.6 Nm @ 5500 rpm 28.5 Nm @ 7000 rpm
Maximum speed (Urban and Rain mode) (Tour and Rally mode)	130 km/h 139 km/h
Engine idling rpm	1500 ± 200 rpm
Idling CO%	CO < 0.5%
Idling HC ppm	HC < 500 ppm
Camshaft	Double over head camshaft
Fuel feed	Closed loop EFI system
Cooling system	Liquid cooling
Air filter	Dry paper filter

Engine

Oil filter	Wire mesh and Micronic paper filter
Lubrication system	Semi-dry sump lubrication
Starting system	Electric starter

Transmission

Clutch system	Wet multi-plate lean segment assist and slipper clutch
Gear shift pattern	One down and five up
Number of gears	Six speed, toe shift
Primary transmission	Spur gears
Secondary transmission	Chain and sprockets
First gear ratio	3.000
Second gear ratio	2.063
Third gear ratio	1.588
Fourth gear ratio	1.286
Fifth gear ratio	1.095
Sixth gear ratio	0.955
Primary reduction	2.885
Secondary reduction	2.875

Dimension

Overall length	2176 mm
Overall width	884 mm
Overall height	1400 mm
Saddle height	835 mm
Ground clearance	200 mm
Wheel base	1428 mm
Kerb weight	Option 1 - 179 kg & Option 2 - 180 kg
Pay load	150 kg
Gross vehicle weight	Option 1 - 329 kg & Option 2 - 330 kg (without accessories) / 345 kg (with accessories)

Frame and Suspension

Frame type	Steel trellis frame hinged with aluminium cast swingarm
Front suspension	USD forks, 41 mm diameter
Rear suspension	Monoshock with floating Piston
Fork stroke length	180 mm
Rear suspension travel	180 mm
Steering angle	38° on both sides
Caster angle	26.5° ± 1°
Turning radius	1320 ± 10 mm
Gradability	10°
Banking angle	52°

Wheels and Brakes

Brakes	
Brakes type	Dual channel ABS, switchable rear
Front brake size	Hand operated 320 mm disc
Rear brake size	Foot operated 240 mm disc
Wheel	
Front tyre make and model	EUROGRIP EXPLO - R PLUS
Rear tyre make and model	EUROGRIP EXLPO - R PLUS
Front tyre size	110/80 - 19 M/C 59H (tubeless)
Rear tyre size	150/70 - R17 M/C 69H (tubeless)
Front tyre pressure	On Road - Solo / dual : 2.25 kg (32 PSI) OFF Road - 2 kg (28 PSI)
Rear tyre pressure	On Road - Solo / dual : 2.25 kg (32 PSI) OFF Road - 2 kg (28 PSI)

Free Plays

Free plays	
Clutch free play	8 - 12 mm
Drive chain free play	20 - 25 mm

Electricals

Type	Three phase AC generator
Ignition system	IDI system with suppressor cap
Spark plug	NGK (LMAR9D - J)
Spark plug gap	0.7 to 0.9 mm
Battery type	12V / 8 Ah MF wet charge type
Body earthing	Two grounds(1 No. engine ground, 1 No. ignition ground)
Generator	12V, 290W
Head lamp	Top Variant - Low beam 24W / High beam 53W @ 13.2V Base Variant - Low beam 27W / High beam 56W @ 13.2V
DRL (Top / BTO only)	17.5W @ 13.5V
FPL	2W @ 13.5V
Tail Lamp + NPL / Brake Lamp+ NPL	2.6W / 7W
Turn signal lamp	13.5V, LED (4W)
Instrument panel	TFT / LED indicators
Horn type	12V, DC two numbers
Fuse	Mini fuse - 7.5A x 2, 10A x 3, 15A x 2, and 30A x 1
Voltage regulator	Three phase full wave shunt regulator

DRL - Day running lamp FPL - Front position lamp NPL - Number plate lamp

Important Torque Details

Front wheel	
Quick release axle locking screw	50 ± 7 Nm
Axle holder clamping screws	19 ± 3 Nm
Caliper assembly mounting bolts	28 ± 4.2 Nm
Rear wheel	
Drive chain adjuster screw lock nuts	19 ± 3 Nm
Rear wheel quick release nut	100 ± 15 Nm
Swing arm	
Swing arm axle mounting nut	135 ± 20.5 Nm
Rear shock absorber top mounting bolt	56 ± 8 Nm
Rear shock absorber bottom mounting bolt	56 ± 8 Nm

Basic Troubleshooting

Difficulty in starting the engine or engine not starting

Possible cause	Rectification
Side stand is in ON and gear engaged	Release the side stand
Engine kill switch is ON	Turn off the engine kill switch (ref. page 43)
Gear applied and clutch not disengaged	Either apply the clutch or bring the transmission to neutral position.
No fuel in the fuel tank	Refuel (ref. page 120)
Battery discharged	Recharge the battery or fix a new battery if the old battery is not getting charged.

Dear Customer,

It is mandatory under the Motor Vehicles Act to insure all motor vehicles. No motor vehicle can be used in a public place without a valid policy of insurance issued by an authorised insurer. Driving a motor vehicle without any such insurance is an offense under Motor Vehicles Act.

To assist our Customers on their insurance requirements such as the prompt issue and renewal of policies as well as expeditious settlement of claims if any, our preferred insurers are:



TVS CONNECT APP



'TVS CONNECT' mobile app of your TVS RTX vehicle can be downloaded from the Google Play and the AppStore® by searching the key word 'TVS CONNECT' else by scanning the below QR code.



Android

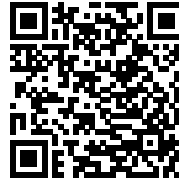

IOS



TVS MOTOR COMPANY LIMITED. P.B. No.4, Harita, Hosur, 635109, Tamil Nadu, India.
Telephone: +91 (4344) 276780. Fax: +91 (4344) 276878 / 277311 www.tvsapache.com